

# Video Projector

## Operating Instructions

Before operating the unit, please read this manual and supplied Quick Reference Manual thoroughly and retain it for future reference.

VPL-VW5000 **ES**

**4K** **SXR**D **HDMI**  
Silicon X-tal Reflective Display

---

# Table of Contents

---

## **Location of Controls**

Front/Right Side .....	3
Rear/Bottom .....	4
Remote Control .....	5

---

## **Connections and Preparations**

Installing the Unit .....	6
Adjusting the Picture Position .....	6
Connecting to Video Equipment or a Computer .....	10
Connecting to a VCR .....	10
Connecting to a Computer .....	11

---

## **Projecting**

Projecting the Picture .....	12
Turning Off the Power .....	12
Watching 3D Video Images .....	12
Using the 3D Glasses .....	12
Using the Picture Position .....	13
Selecting the Aspect Ratio According to the Video Signal .....	14
Selecting the Picture Viewing Mode .....	16

---

## **Using the Menus**

Operation through the Menus .....	17
Picture Menu .....	19
Advanced Picture Menu .....	23
Screen Menu .....	24
Setup Menu .....	26
Function Menu .....	28
Items Locked by Settings Lock .....	30
Installation Menu .....	31
Information Menu .....	33
About the Preset Memory .....	33

---

## **Using Network Features**

Displaying the Control Window of the Unit with a Web Browser .....	34
Operating the Control Window .....	35
Switching the Page .....	35
Setting the Access Limitation .....	35
Confirming the Information Regarding the Unit .....	35

---

## **Error Handling**

Troubleshooting .....	36
About Indicators .....	38
Message Lists .....	39

---

## **Others**

Updating the Software .....	40
About HDR (high dynamic range) .....	40
About DCI specification .....	40
About x.v.Color .....	40
About the Simulated 3D Feature .....	40
Specifications .....	41
Preset Signals .....	42
Input Signals and Adjustment/Setting Items .....	43
Compatible 3D Signals .....	43
Aspect Mode .....	44
Storage Conditions of Adjustment/Setting Items .....	44
Projection Distance and Lens Shift Range .....	46
Dimensions .....	50
NOTICES AND LICENCES FOR SOFTWARE USED IN THIS PRODUCT ....	51
Index .....	59

# Location of Controls

## Front/Right Side

The buttons on the control panel function the same as those on the remote control.

Control panel

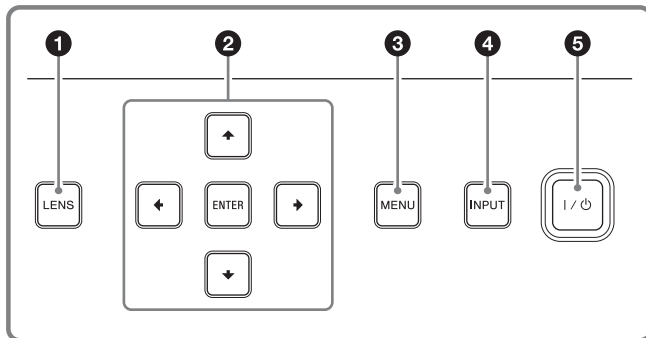

Connectors

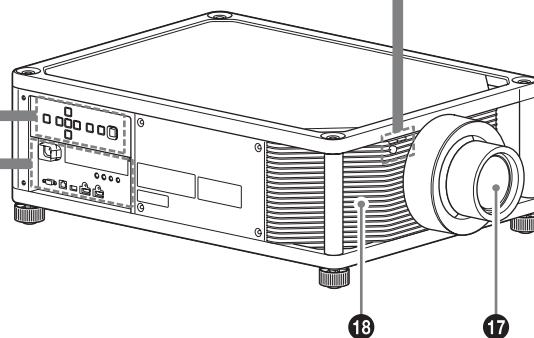
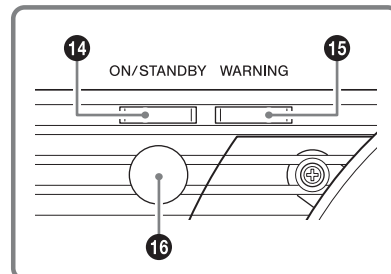
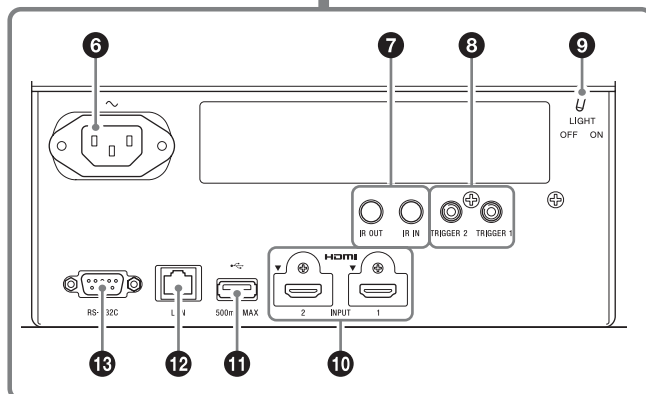

### Control panel

- ❶ LENS button (page 6)
- ❷ ↑/↓/←/→ (arrow)/ENTER button (page 17)
- ❸ MENU button (page 17)
- ❹ INPUT button (page 12)
- ❺ I/⏻ (On/Standby) button (page 7)

### Connectors

- ❻ ~ AC IN socket (page 7)

### ❼ IR IN/IR OUT connector

IR IN: Inputs the signals to control the projector. When connecting to the IR IN connector, the remote control detector does not work with the remote control.

IR OUT: Outputs the control signals received at the projector to the connected devices. When operating the projector with the remote control, the connected devices can also be operated.

### ❽ TRIGGER 1/TRIGGER 2 connector (page 31)

### ❾ Connector light switch

Turns on/off the connector lights.

### ❿ HDMI 1/HDMI 2 connector (page 10)

### ⓫ USB connector (page 40)

### ⓬ LAN connector (page 34)

**13 REMOTE connector**

Connects to a computer, etc. for remote control.

---

**Indicators and remote control detector**

**14 ON/STANDBY indicator (page 38)**

**15 WARNING indicator (page 38)**

**16 Remote control detector (page 6)**

---

**Others**

**17 Lens**

**18 Ventilation holes (intake)**

**Note**

If you look through the projection lens while the unit is projecting, the light may damage your eyes. Take special caution when using the unit around children.

---

## Rear/Bottom

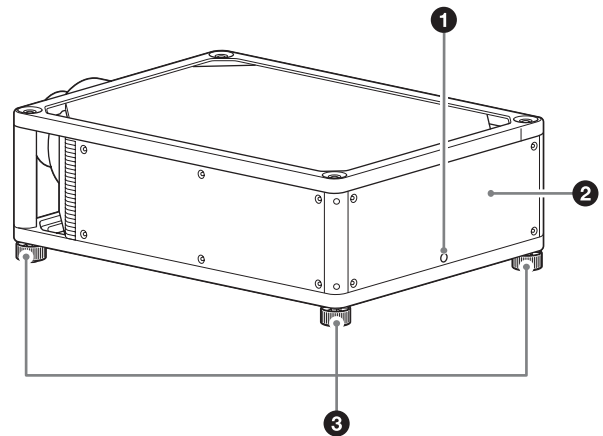

**1 Remote control detector (page 6)**

**2 Ventilation holes (exhaust)**

**3 Feet (adjustable) (page 8)**

# Remote Control

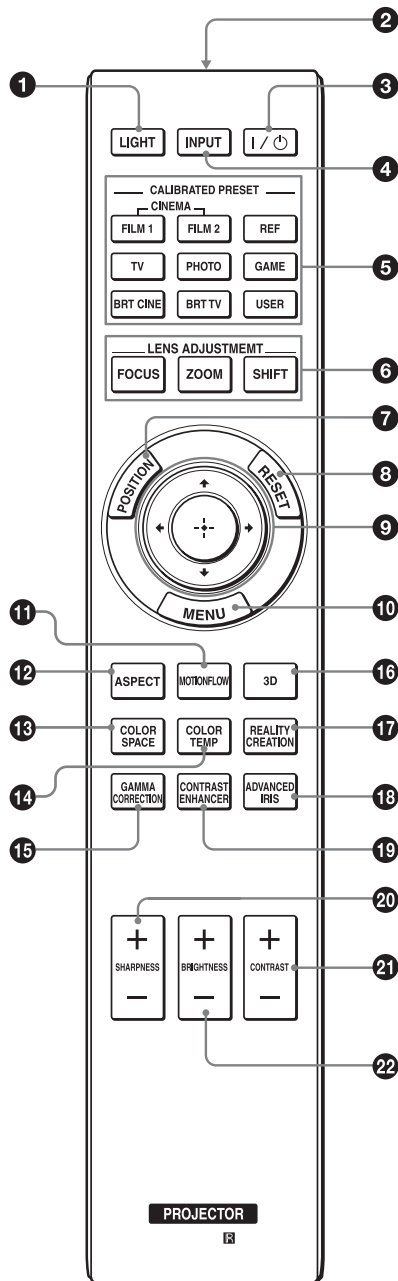

- ❶ **LIGHT button**  
Illuminates the buttons on the remote control.
- ❷ **Infrared transmitter**
- ❸ **I/⏻ (On/Standby) button (page 7)**
- ❹ **INPUT button (page 12)**
- ❺ **CALIBRATED PRESET buttons (page 16)**
- ❻ **LENS ADJUSTMENT buttons (page 7)**
- ❼ **POSITION button (page 13)**
- ❽ **RESET button (page 18)**
- ❾ **↑/↓/←/→ (arrow)/ ⊕ (enter) buttons (page 17)**
- ❿ **MENU button (page 17)**
- ⓫ **MOTIONFLOW button (page 20)**
- ⓬ **ASPECT button (page 14)**
- ⓭ **COLOR SPACE button (page 22)**
- ⓮ **COLOR TEMP button (page 20)**
- ⓯ **GAMMA CORRECTION button (page 21)**
- ⓰ **3D button (page 12)**
- ⓱ **REALITY CREATION button (page 19)**
- ⓲ **ADVANCED IRIS button**  
This function is not provided in this projector.
- ⓳ **CONTRAST ENHANCER button (page 20)**
- ⓴ **SHARPNESS button (page 20)**
- ⓵ **CONTRAST button (page 20)**
- ⓶ **BRIGHTNESS button (page 20)**

# Connections and Preparations

This section describes how to install the unit and screen, how to connect the equipment from which you want to project the picture, etc.

## Installing the Unit

The installation distance between the unit and a screen varies depending on the size of the screen or whether or not you use the lens shift features. Install this unit so that it fits the size of your screen. For details on the distance between the unit and the screen (the projection distance) and the size of projected video, see “Projection Distance and Lens Shift Range” (page 46).

- 1 Position the unit so that the lens is parallel to the screen.

Top view

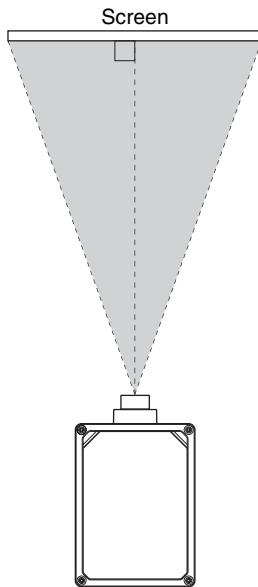

- 2 Project an image on the screen and adjust the picture so that it fits the screen (page 6).

### Note

When using a screen with an uneven surface, stripes pattern may rarely appear on the screen depending on the distance between the screen and the unit or the zooming magnifications. This is not a malfunction of the unit.

## Adjusting the Picture Position

Project an image on the screen and then adjust the picture position.

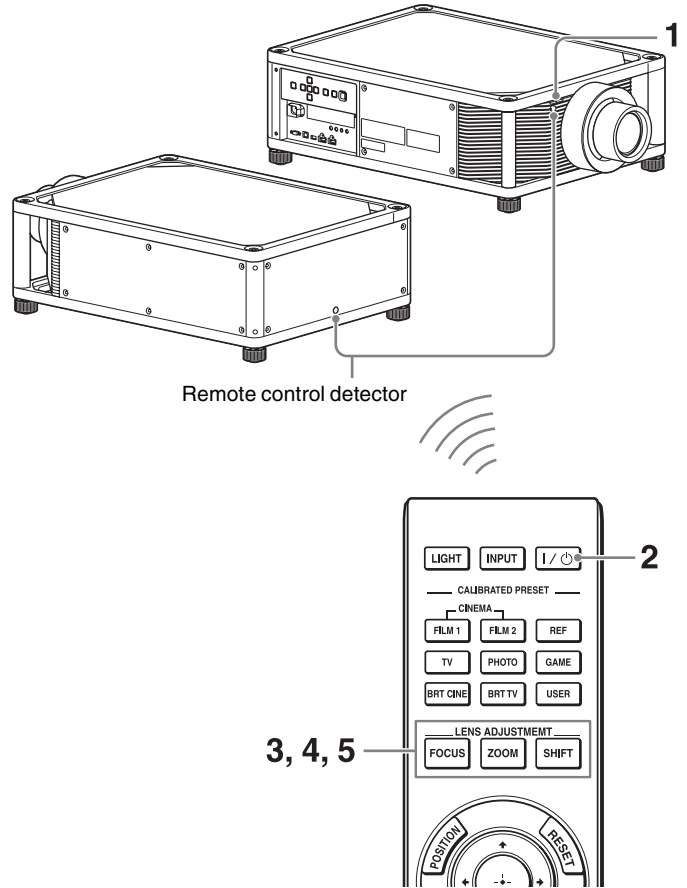

### Tips

- The I/ON (On/Standby), INPUT, MENU, and  $\uparrow/\downarrow/\leftarrow/\rightarrow$ /ENTER buttons on the side panel of the unit function the same as those on the remote control. The LENS button functions in the same way as the LENS ADJUSTMENT (FOCUS, ZOOM, SHIFT) buttons of the remote control.
- When adjusting the lens, each time you press the LENS button on the unit, the lens adjustment function switches between “Lens Focus,” “Lens Zoom” and “Lens Shift.”

FOCUS → ZOOM → SHIFT  
 $\uparrow$  —————  $\downarrow$

**Note**

Depending on the installation location of the unit, you may not be able to control it with the remote control. In this case, point the remote control at the remote control detector of the unit or the screen.

- 1 After connecting the AC power cord to the unit, plug the AC power cord into a wall outlet.  
The ON/STANDBY indicator lights in red and the unit goes into standby mode.

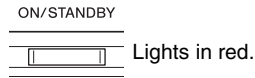

- 2 Press the I/⏻ (On/Standby) button to turn on the unit.

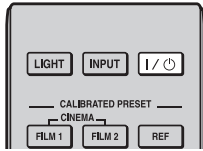

The ON/STANDBY indicator flashes in green, and then lights in green.

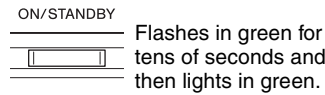

- 3 Adjust the focus.  
Press the LENS ADJUSTMENT (FOCUS) button to display the Lens Focus adjustment window (test pattern). Then adjust the focus of the picture by pressing the ↑/↓/←/→ buttons.

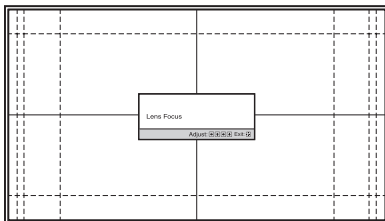
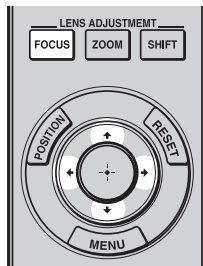

**Tips**

- When “Lens Control” is set to “Off” on the Installation menu, you cannot adjust the focus, the picture size or the proper position by pressing the FOCUS, ZOOM or SHIFT buttons (page 31).
- When “Test Pattern” is set to “Off” on the Function menu, the test pattern is not displayed (page 29).

**Note**

Adjust the lens by using buttons on the remote control or the control panel of the unit. Never make adjustments by directly turning the lens with your hands, which may cause damage or malfunction to the unit.

- 4 Adjust the picture size.  
Press the LENS ADJUSTMENT (ZOOM) button to display the Lens Zoom adjustment window (test pattern). Then adjust the size of the picture by pressing the ↑/↓/←/→ buttons.

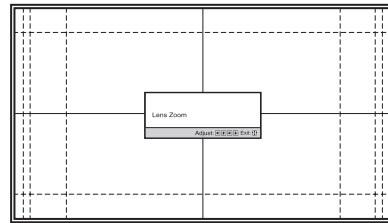
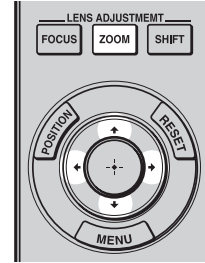

To make the picture larger, press ↑/→.  
To make the picture smaller, press ↓/←.

- 5 Adjust the picture position.  
Press the LENS ADJUSTMENT (SHIFT) button to display the Lens Shift adjustment window (test pattern). Then adjust to the proper position of the picture by pressing the ↑/↓/←/→ buttons.

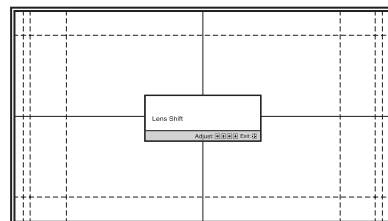
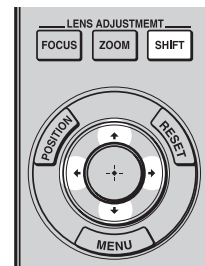

**Tip**

Whenever you press the button, the test pattern disappears.

**Note**

When adjusting the picture position, do not touch the lens unit, otherwise your fingers may be pinched by the moving parts.

**To adjust the horizontal position**

Press ←/→.

The picture projected on the screen moves right or left by a maximum of 31% of the screen width from the center of the lens.

**Top view**

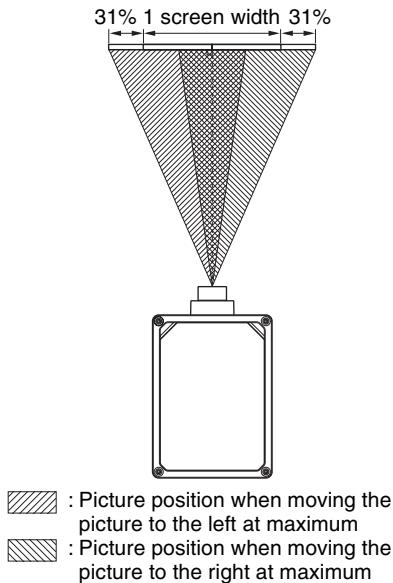

**Note**

The range to move the picture projected on the screen can be adjusted only within the octagon area illustrated below. For details, see “Projection Distance and Lens Shift Range” (page 46).

**Range of movement of the projected picture**

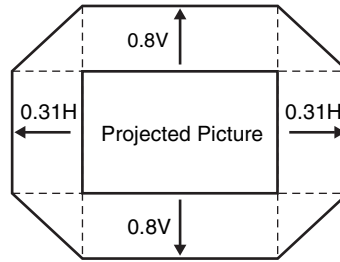

H: Width of the projected picture  
V: Height of the projected picture

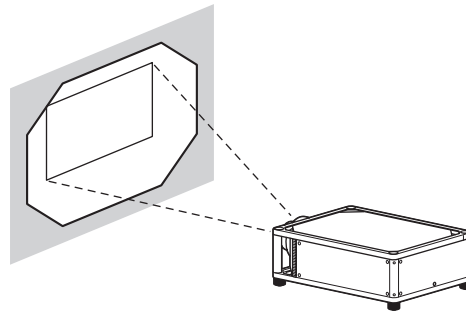

**To adjust the tilt of the installation surface**

If the unit is installed on an uneven surface, use the feet (adjustable) to keep the unit level.

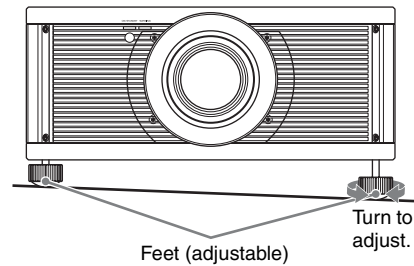

**To adjust the vertical position**

Press ↑/↓.

The picture projected on the screen moves up or down by a maximum of 80% of the screen height from the center of the lens.

**Side view**

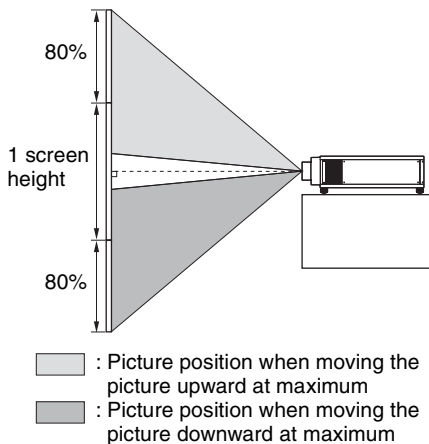

**Notes**

- If the unit is tilted up or down, the projected image may be trapezoidal.
- Be careful not to catch your finger when turning the feet (adjustable).

# Lens adjustment window (test pattern)

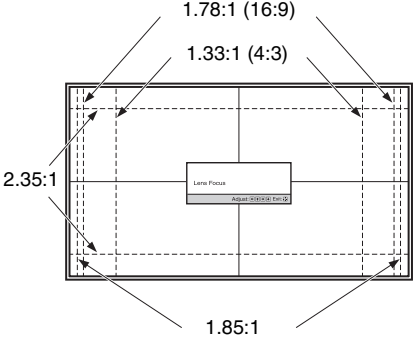

The dashed lines show the screen sizes of each aspect ratio.

# Connecting to Video Equipment or a Computer

You can enjoy high picture quality by connecting a DVD player/recorder, Blu-ray Disc player/recorder, or PlayStation® equipped with HDMI output to the HDMI input of the unit.

## When making connections, be sure to do the following:

- Turn off all equipment before making any connections.
- Use the proper cables for each connection.
- Insert the cable plugs properly; poor connection at the plugs may cause a malfunction or poor picture quality. When pulling out a cable, be sure to pull it out from the plug, not the cable itself.
- Refer to the operating instructions of the connected equipment.

## Connecting to a VCR

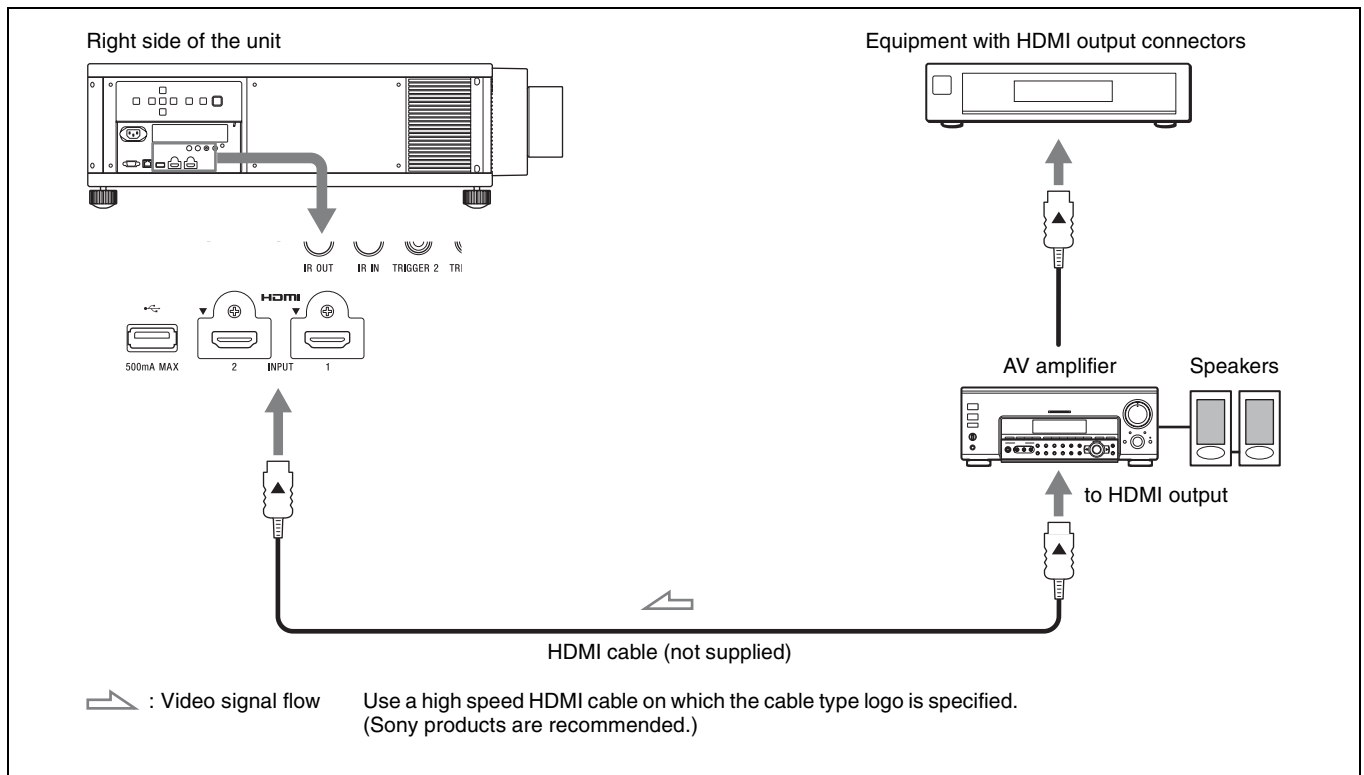

## Notes

- Use a high-speed HDMI cable. With a standard HDMI cable, images of 1080p, DeepColor, 3D video and 4K video may not be displayed properly.
- When connecting an HDMI cable to the unit, make sure the ▼ mark on the upper part of the HDMI input of the unit and the ▲ mark on the connector of the cable are faced at each other.
- If the picture from equipment connected to the unit with an HDMI cable is not correct, check the settings of the connected equipment.

## Connecting to a Computer

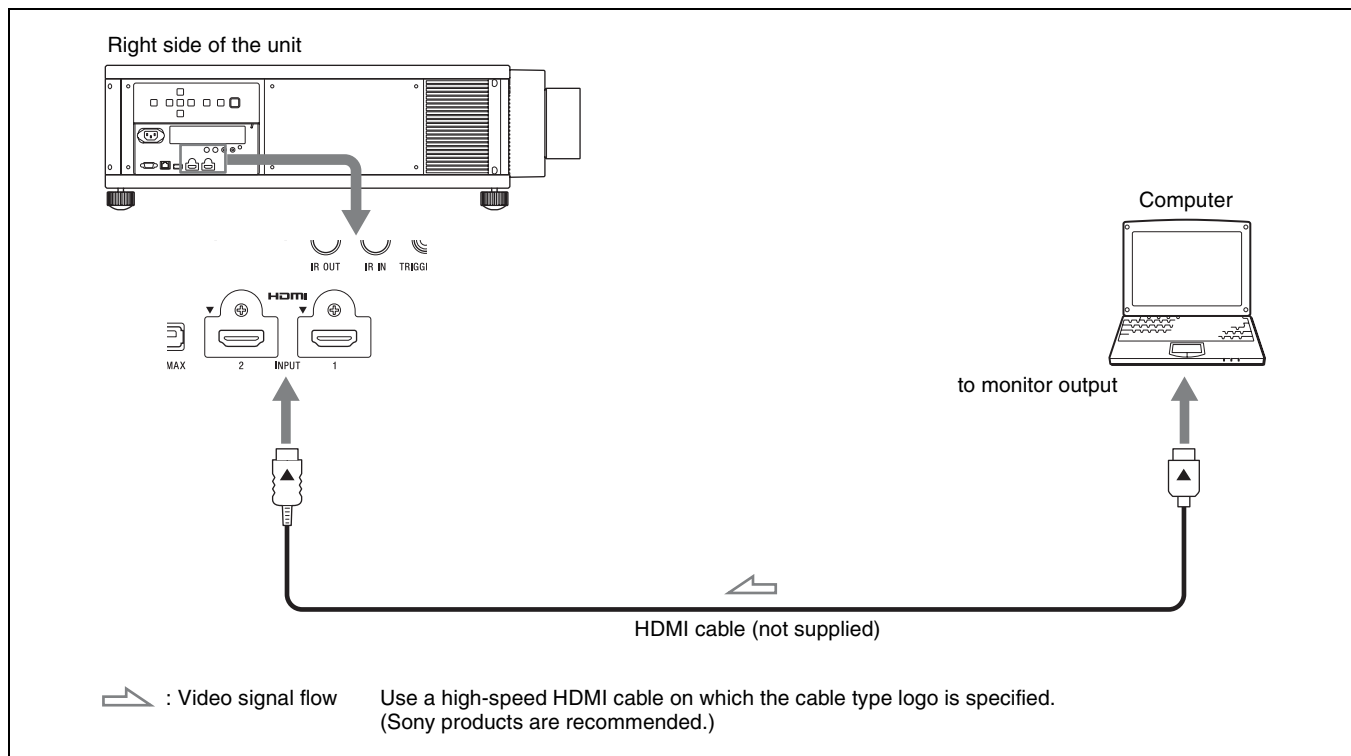

### Notes

- Use a high-speed HDMI cable. With a standard HDMI cable, images of 1080p, DeepColor, 3D video and 4K video may not be displayed properly.
- When connecting an HDMI cable to the unit, make sure the ▼ mark on the upper part of the HDMI input of the unit and the ▲ mark on the connector of the cable are faced at each other.
- If the picture from equipment connected to the unit with an HDMI cable is not correct, check the settings of the connected equipment.
- If you set your computer, such as a notebook type, to output the signal to both computer's display and this equipment, the picture of the equipment may not appear properly. Set your computer to output the signal to only the external monitor. For details, refer to the computer's operating instructions supplied with your computer. For settings of the computer, consult with the manufacturer of the computer.

# Projecting

This section describes how to operate the unit to view a picture from the equipment connected to the unit. It also describes how to switch the screen size according to the picture.

## Projecting the Picture

- 1 Turn on both the unit and the equipment connected to the unit.
- 2 Press INPUT to display the input palette on the projection surface.

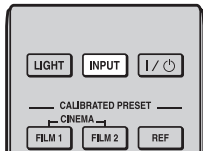

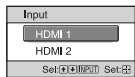

- 3 Select the equipment from which you want to display images.  
Press INPUT repeatedly or press  $\uparrow/\downarrow/\oplus$  (enter) to select the equipment from which to project.



Example: To view the picture from the video equipment connected to the HDMI 1 connector of this unit.

### Tips

- When “Status” is set to “Off” on the Setup  menu, the input palette does not appear. Press the INPUT button to switch between input terminals sequentially.
- You can change the language for the menu and on-screen displays in “Language” on the Setup  menu (page 26).

## Turning Off the Power

- 1 Press the I/O (On/Standby) button.  
The message “POWER OFF?” appears.
- 2 Press the I/O (On/Standby) button again before the message disappears.  
The ON/STANDBY indicator flashes in green and the fan continues to run to reduce the internal heat.

The fan stops and the ON/STANDBY indicator changes from flashing green to remaining red.

You can disconnect the AC power cord.

### Note

Never disconnect the AC power cord while the unit is turned on.

You can turn off the unit by holding the I/O (On/Standby) button for about 1 second, instead of performing the above steps.

## Watching 3D Video Images

You can enjoy powerful 3D video images, such as from 3D games and 3D Blu-ray Discs, using the optional Active 3D Glasses (TDG-BT500A).

- 1 Turn on the HDMI equipment for 3D compatibility connected to the unit, then play the 3D content.  
For details on how to play 3D content, refer to the operating instructions for the connected equipment.
- 2 Turn on the unit and project the 3D video image.  
For details on how to project the image, see “Projecting the Picture” (page 12).
- 3 Turn on the 3D glasses, and then put them on so that they fit comfortably.  
For details on how to use the 3D glasses, see “Using the 3D Glasses” (page 12).

### Tip

The factory default setting for “2D-3D Display Sel.” is “Auto” to allow projecting 3D video images automatically when the unit detects 3D signals.

### Notes

- It may not be possible to display 3D video image, depending on the type of signal. Set the “2D-3D Display Sel.” to “3D,” and “3D Format” to “Side-by-Side” or “Over-Under” to suit the format of the 3D content you want to watch (page 28).
- Use the 3D glasses within the communication range (page 13).
- There are differences in perception of 3D video images among individuals.
- When the temperature of the usage environment is low, the 3D effect may be diminished.

## Adjusting/Setting the 3D functions

You can adjust/set the 3D functions by pressing the 3D button on the remote control or with the “3D Settings” of the Function  menu. For details, see “3D Settings” (page 28).

## Using the 3D Glasses

- 1 Turn on the 3D glasses, and register them on the unit.  
For details on how to register the 3D glasses, refer to the operating instructions supplied with the 3D glasses.

## 2 Put on the 3D glasses.

### Precautions for use

Misoperation may occur if:

- The viewing position is too far from the projector
- There are other communication devices, such as a wireless LAN (IEEE802.11 b/g/n) or a microwave with a bandwidth of 2.4 GHz, near the unit

### 3D glasses communication range

The following figure indicates the communication range of the 3D glasses. If you try to watch 3D video images from a distance greater than the communication range or install the unit outside the communication range, the 3D glasses may not be able to display the images properly. Also, the distance varies depending on the environment of the room and installation environment of the unit.

### Top or side view

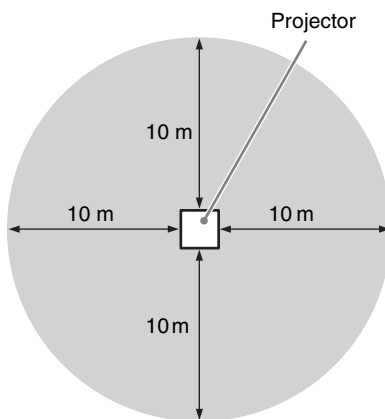

## Using the Picture Position

You can store up to five combinations of lens settings (focus, picture size, picture position), aspect ratio, and blanking. These settings can be recalled.

### 1 Press POSITION.

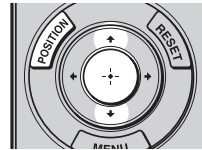

The Picture Position selecting palette is displayed.

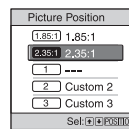

### 2 Press POSITION repeatedly, or press $\uparrow/\downarrow/\oplus$ to select the position.

The settings of the position selected is recalled. Store or delete lens settings, aspect ratio, and blanking in the "Picture Position" of the Screen  $\oplus$  menu (page 24).

The position where the lens settings, aspect ratio, and blanking are not stored is displayed as "---."

### Image of the lens moving

In the example below, the images with aspect ratio of 1.78:1 (16:9) and 2.35:1 are projected on a 2.35:1 screen.

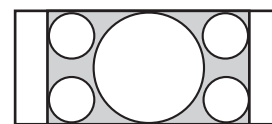

When a 1.78:1 (16:9) image is input



When a 2.35:1 image is input

Press the POSITION button.

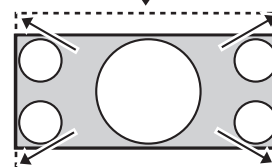

The 2.35:1 image expands to fill the screen.

**Notes**

- After you have selected and confirmed the lens position, the lens starts to move. Do not touch, or place anything near, the lens, otherwise it may cause injury or a malfunction.
- If you press any button on the remote control or the unit while the lens is moving, the lens stops. In this case, select the lens position again or adjust the lens manually.
- The Picture Position function is not guaranteed to reproduce the lens settings precisely.
- When you use the subtended screen angle of two or more aspects using lens zoom, install the unit within the specified parameters referring to “Projection distance” (page 47). With some setting positions, the range of lens shift may be restricted, even though the unit is installed within the specified parameters.

# Selecting the Aspect Ratio According to the Video Signal



You can select an aspect ratio best suited for the video signal received.

Press ASPECT.

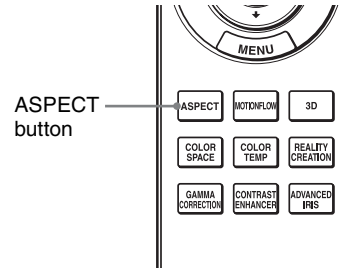
Each time you press the button, you can select the “Aspect” setting. You can also select it using the menu (page 25).

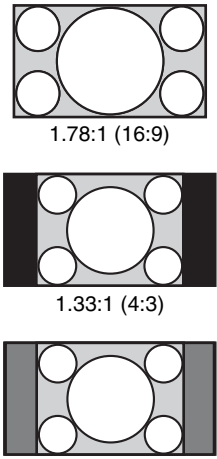
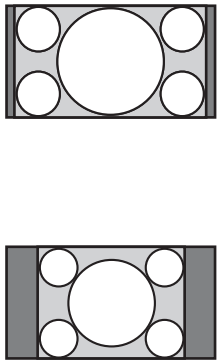

Original image (for 16:9 display)	Recommended setting and resultant images
<p>1.85:1</p> <p>Squeezed 1.85:1</p>	<p>1.85:1 Zoom</p>
<p>2.35:1</p> <p>Squeezed 2.35:1</p>	<p>2.35:1 Zoom</p>

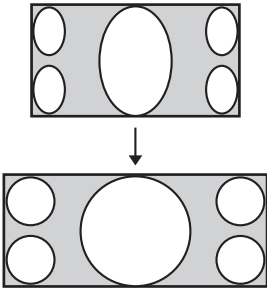
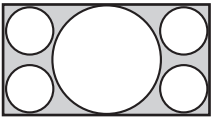
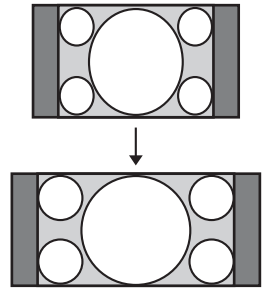
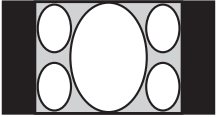
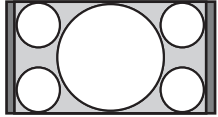
Original image (for 16:9 display)	Recommended setting and resultant images
 <p>1.78:1 (16:9)</p> <p>1.33:1 (4:3)</p> <p>1.33:1 (4:3) with side panels</p>	<p>Normal</p> 
 <p>2.35:1</p>	<p>V Stretch</p>  <p>When using an anamorphic lens</p>
 <p>16:9</p>	<p>Squeeze</p>  <p>When using an anamorphic lens</p>
 <p>Squeezed</p>	<p>Stretch</p> 

**Note**

Selectable aspect modes vary depending on the input signal (page 44).

**Notes on switching the “Aspect” setting**

- Select the aspect mode taking into account that changing the aspect ratio of the original picture will provide a different look from that of the original image.
- Note that if the unit is used for profit or for public viewing, modifying the original picture by switching the aspect may constitute an infringement of the rights of authors or producers, which are legally protected.

# Selecting the Picture Viewing Mode

You can select the picture viewing mode that best suits the type of video source or room conditions.

You can save and use different preset modes for 2D/3D respectively.

Press one of the CALIBRATED PRESET buttons.

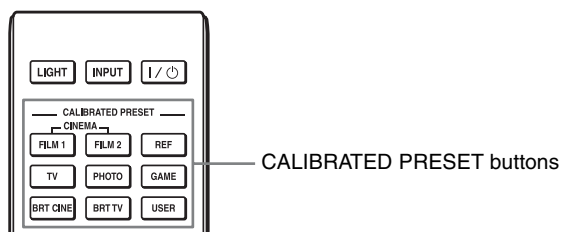

Setting items	Description
CINEMA FILM 1	Picture quality suited to reproducing the highly dynamic and clear images typical of master positive film.
CINEMA FILM 2	Picture quality suited for HDR content, with the highest dynamic range and many colors.
CINEMA DIGITAL *1	Picture quality suited to reproducing digital cinema-like images resembling DCI specifications (page 40).
REF	A picture quality setup suitable for when you want to reproduce faithfully the original image quality, or for enjoying image quality, without any adjustment.
TV	Picture quality suited for watching TV programs, sports, concerts, and other video images.
PHOTO	Ideal for projecting still images taken with a digital camera.
GAME	Picture quality suited to gaming, with well-modulated colors and fast response.
BRT CINE	Picture quality suited for watching movies in a bright environment, such as a living room.
BRT TV	Picture quality suited for watching TV programs, sports, concerts, and other video images in a bright environment, such as a living room.
USER1, USER2, USER3 *2	Adjusts the picture quality to suit your taste then saves the setting. The factory default setting is the same as “REF.”

\*1: The CINEMA DIGITAL mode is not available on the remote control.

\*2: The USER1 mode is selected by pressing the USER button. The USER2 mode and USER3 mode are not available on the remote control.

# Using the Menu

This section describes how to make various adjustments and settings using the menus.

## Note

The menu displays used for the explanation may be different from the actual menu display.

## Operation through the Menu

The unit is equipped with an on-screen menu for making various adjustments and settings. If you select an item name followed by an arrow (▶), the next menu window with setting items appears.

- 1 Press MENU.

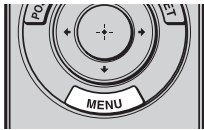

The menu window appears.

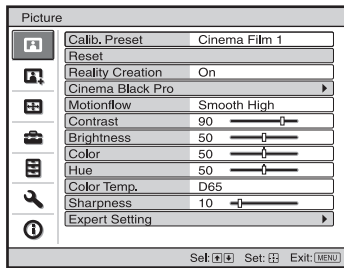

- 2 Press  $\uparrow/\downarrow$  to select a menu item, and press  $\rightarrow$  or  $\odot$ .

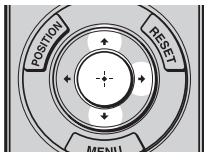

The items that can be set or adjusted with the selected menu appear. The item presently selected is shown in white.

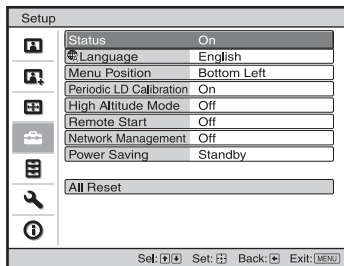

- 3 Press  $\uparrow/\downarrow$  to select an item you want to set or adjust and press  $\rightarrow$  or  $\odot$ .

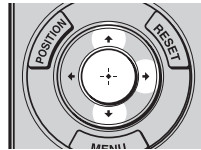

The setting items are displayed in a pop-up menu, in a setting menu, in an adjustment menu or in the next menu window.

## Pop-up menu

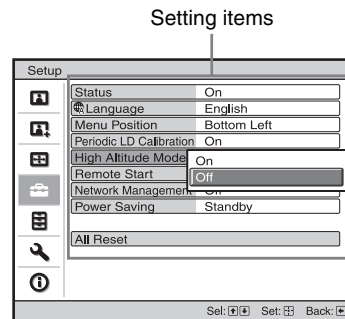

## Setting menu

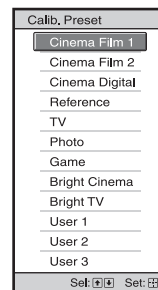

## Adjustment menu

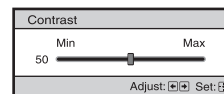

## Next menu window

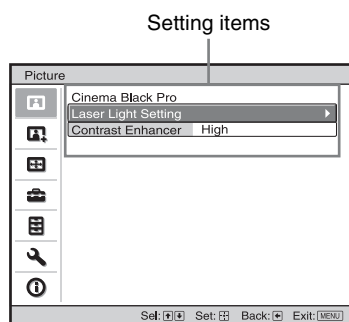

- 4** Make the setting or adjustment of an item.

### When changing the adjustment level

To increase the value, press **↑/→**.

To decrease the value, press **↓/←**.

Press **⊕** to store the setting and restore the original menu screen.

### When changing the setting

Press **↑/↓** to change the setting.

Press **⊕** to restore the original screen.

You can restore the original screen using **←** depending on the selected item.

---

## To clear the menu

Press MENU.

---

## To reset the picture that has been adjusted

Select “Reset” from the Picture **Ⓐ** menu.

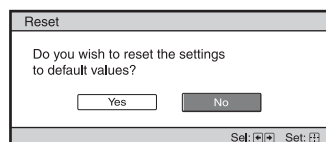

When the screen display appears, select “Yes” using **←** and press **⊕**.

All of the following settings are reset to its factory preset value:

“Reality Creation,” “Cinema Black Pro,” “Motionflow,” “Contrast,” “Brightness,” “Color,” “Hue,” “Color Temp.,” “Sharpness,” and “Expert Setting” on the Picture **Ⓐ** menu

---

## To reset the items that have been adjusted

Select an item in the menu screen, and display the pop-up menu, the setting menu, or the adjustment menu.

Press RESET on the remote control to reset only the selected settings to its factory preset value.

### Note

The RESET button on the remote control is available only when the adjustment menu or the setting menu is selected.

# Picture Menu

The Picture menu is used for adjusting the picture.

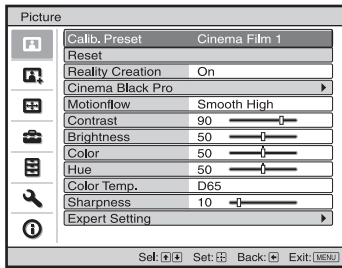

Item names in brackets represent those printed on the remote control.

Setting items	Description
Calib. Preset [CALIBRATED PRESET]	<p>You can select the picture viewing mode that best suits the type of video source or the environment. You can save and use different preset modes for 2D/3D respectively.</p> <p><b>Cinema Film 1:</b> Picture quality suited to reproducing the highly dynamic and clear images typical of master positive film.</p> <p><b>Cinema Film 2:</b> Picture quality suited for HDR content, with the highest dynamic range and many colors.</p> <p><b>Cinema Digital:</b> Picture quality suited to reproducing digital cinema-like images resembling DCI specifications (page 40).</p> <p><b>Reference:</b> A picture quality setup suitable for when you want to reproduce faithfully the original image quality, or for enjoying image quality, without any adjustment.</p> <p><b>TV:</b> Picture quality suited for watching TV programs, sports, concerts, and other video images.</p> <p><b>Photo:</b> Ideal for projecting still images taken with a digital camera.</p> <p><b>Game:</b> Picture quality suited to gaming, with well-modulated colors and fast response.</p> <p><b>Bright Cinema:</b> Picture quality suited for watching movies in a bright environment, such as a living room.</p> <p><b>Bright TV:</b> Picture quality suited for watching TV programs, sports, concerts, and other video images in a bright environment, such as a living room.</p> <p><b>User 1, User 2, User 3:</b> You can adjust the picture quality to suit your taste, and save the setting. The factory default setting is the same as “Reference.”</p> <p><b>Tip</b> Any adjustments to picture quality settings are saved for each input.</p>
Reset	<p>Resets all currently selected Calib. Preset mode settings to their default values (page 18).</p> <p><b>Tip</b> Reset does not affect settings saved for the Custom 1 to 5 items of “Color Temp.”</p>
Reality Creation [REALITY CREATION]	<p>Adjusts the detail and noise processing of images. (Super-resolution function)</p> <p><b>On:</b> Adjusts the settings of “Reality Creation.”</p> <p><b>Database:</b> Select “Normal” or “Mastered in 4K.”</p> <p>“Mastered in 4K” provides image quality suitable for Blu-ray Disc™ “Mastered in 4K” releasing from Sony Pictures Home Entertainment.</p> <p><b>Resolution:</b> When you increase the setting value, the texture and detail of the picture become sharper.</p> <p><b>Noise Filtering:</b> When you increase the setting value, the noise (picture roughness) becomes less prominent.</p> <p><b>Test: On/Off:</b> Changes “On” and “Off” at a certain frequency to check the effect of “Reality Creation.”</p> <p><b>Tip</b> The display position of status during the test works together with the “Menu Position” setting (page 26).</p> <p><b>Off:</b> The “Reality Creation” function is not applied.</p>

Setting items	Description
Cinema Black Pro	
Laser Light Setting	<p><b>Dynamic Control:</b> Adjusts the range of movement of the laser light control.</p> <p><b>Full:</b> Automatically optimizes the laser light control and signal processing according to the brightness level of the input source. This results in a bright and high contrast image.</p> <p><b>Limited:</b> Suppresses the movement and brightness of the laser light control, making the picture quality suitable for viewing in a dark room.</p> <p><b>Off:</b> The “Dynamic Control” function is not applied.</p> <p><b>Output:</b> The higher the setting, the brighter the picture. The lower the setting, the darker the picture.</p> <p><b>Tip</b> Adjust “Output” according to the brightness of the picture.</p>
Contrast Enhancer [CONTRAST ENHANCER]	<p>Corrects the level of bright and dark parts automatically to optimize contrast according to a scene. Increases image sharpness and makes image dynamic.</p> <p><b>High/Middle/Low:</b> You can adjust the contrast enhancer.</p> <p><b>Off:</b> The contrast enhancer function is not applied.</p>
Motionflow [MOTIONFLOW]	<p><b>Impulse:</b> Reproduces original picture quality. Provides cinema-like picture, which may flicker.</p> <p><b>Combination:</b> Reduces motion blur while maintaining brightness for high-speed picture content.</p> <p><b>Smooth High:</b> Provides smoother picture movement; especially effective for film-based content.</p> <p><b>Smooth Low:</b> Provides smoother picture movement for standard use.</p> <p><b>True Cinema:</b> Images, such as a movie created in 24 frames per second, are reproduced at the original framerate.</p> <p><b>Off:</b> The “Motionflow” function is not applied.</p> <p><b>Tips</b></p> <ul style="list-style-type: none"> <li>• Select “Off” if the selected “Smooth High,” “Smooth Low,” “Impulse,” “Combination,” or “True Cinema” results in a distorted picture.</li> <li>• When selecting “Impulse,” the picture becomes dark. Also, it may flicker.</li> <li>• Depending on the picture content, you may not see the effect visually even if you have changed the settings.</li> <li>• Only “Off” or “Impulse” is available when a signal with a resolution of 4096 × 2160 is input.</li> </ul>
Contrast [CONTRAST]	<p>Adjusts the contrast.</p> <p>Higher values increase the sharpness in images, while lower values decrease the sharpness.</p>
Brightness [BRIGHTNESS]	<p>Adjusts the brightness of the picture.</p> <p>The higher the setting, the brighter the picture. The lower the setting, the darker the picture.</p>
Color	<p>Adjusts the color density.</p> <p>The higher the setting, the greater the intensity. The lower the setting, the lower the intensity.</p>
Hue	<p>Adjusts the color tone.</p> <p>The higher the setting, the more greenish the picture becomes. The lower the setting, the more reddish the picture becomes.</p>
Color Temp. [COLOR TEMP]	<p>Adjusts the color temperature.</p> <p><b>D93:</b> Equivalent to 9,300 K color temperature normally used in TVs. Gives white colors a blue tint.</p> <p><b>D75:</b> Equivalent to 7,500 K color temperature used as an ancillary standard illuminant. Gives a neutral tint between “D93” and “D65.”</p> <p><b>D65:</b> Equivalent to 6,500 K color temperature used as a standard illuminant. Gives white colors a red tint.</p> <p><b>DCI:</b> DCI specification (page 40) color temperature.</p> <p><b>D55:</b> Equivalent to 5,500 K color temperature used as an ancillary standard illuminant. Gives white colors an even redder tint.</p> <p><b>Custom 1 to 5:</b> Enables you to adjust, set, and store your favorite color temperature. The factory default settings are as follows.</p> <p><b>Custom 1:</b> Same as the “D93” color temperature setting.</p> <p><b>Custom 2:</b> Same as the “D75” color temperature setting.</p> <p><b>Custom 3:</b> Same as the “D65” color temperature setting.</p> <p><b>Custom 4:</b> Same as the “DCI” color temperature setting.</p> <p><b>Custom 5:</b> Setting that prioritizes brightness.</p> <p><b>Tip</b> You can adjust each item to a color temperature according to your preference.</p>
Sharpness [SHARPNESS]	<p>Sharpens the outline of the picture, or reduces the noise.</p> <p>The higher the setting, the sharper the picture. The lower the setting, the softer the picture, thus reducing the noise.</p>

Setting items	Description
Expert Setting	
NR (Noise Reduction)	<p>Reduces the roughness or noise of the picture.  <b>Auto:</b> Detects the noise level to reduce the roughness or noise of the picture automatically.  <b>High/Middle/Low:</b> Select a setting according to the roughness or noise of the input signal source.  <b>Off:</b> The NR (noise reduction) function is not applied.</p> <p><b>Tip</b>  The noise level may not be detected accurately with “Auto” depending on the input signal source. If the picture is unacceptable with “Auto,” select a setting from among “High,” “Middle,” “Low” or “Off.”</p>
MPEG NR (MPEG Noise Reduction)	<p>Reduces block noise and mosquito noise, particularly in digital signals.  <b>Auto:</b> Detects the noise level to reduce the block noise and mosquito noise of the picture automatically.  <b>High/Middle/Low:</b> Select a setting according to the block noise and mosquito noise of the input signal source.  <b>Off:</b> The MPEG NR (MPEG noise reduction) function is not applied.</p> <p><b>Tip</b>  The noise level may not be detected accurately with “Auto” depending on the input signal source. If the picture is unacceptable with “Auto,” select a setting from among “High,” “Middle,” “Low” or “Off.”</p>
Smooth Gradation	<p>Smooths the gradation of the flat parts of images.  <b>High/Middle/Low:</b> You can adjust the smooth gradation effect.  <b>Off:</b> The smooth gradation function is not applied.</p>
Film Mode	<p>According to the film source you have selected, make a setting for playback.  <b>Auto:</b> Suitable for reproducing the original picture movement. Normally, set this to “Auto.”  <b>Off:</b> Plays back the picture in progressive format without detecting video signals automatically.</p> <p><b>Tip</b>  This item is compatible with a 1080i signal only.</p>
Gamma Correction [GAMMA CORRECTION]	<p>Adjusts the response characteristics of the tone of the picture.  Select a favorite tone from 10 options.</p> <p>1.8: Bright Produces a brighter picture overall.  2.0  2.1  2.2  2.4  2.6: Dark Produces a darker picture overall.</p> <p><b>Gamma 7:</b> Simulates the gamma curve of film.  <b>Gamma 8:</b> Increases the sharpness in images. Select this when you watch in a bright environment, such as a living room.  <b>Gamma 9:</b> Produces a brighter picture than Gamma 8.  <b>Gamma 10:</b> Increases the sharpness in images. Select this when you watch TV programs, etc., in a bright environment, such as a living room.  <b>Off:</b> The “Gamma Correction” function is not applied.</p>
Color Correction	<p><b>On:</b> Adjusts Hue, Saturation and Brightness of the selected colors.  Repeat steps ① and ② described below to specify the target color.  ① Press <b>↑/↓</b> to select “Color Select,” then press <b>←/→</b> to select the color you want to adjust among “Red,” “Yellow,” “Green,” “Cyan,” “Blue,” and “Magenta.”</p> <div data-bbox="652 1472 927 1600" data-label="Image"> </div> <p>② Press <b>↑/↓</b> to select “Hue,” “Saturation” or “Brightness,” then adjust them to suit your taste using <b>←/→</b> while watching the projected picture.  <b>Off:</b> The “Color Correction” effect is not applied.</p>
Clear White	<p>Emphasizes vivid whites.  <b>High/Low:</b> You can adjust the “Clear White” effect.  <b>Off:</b> The “Clear White” effect is not applied.</p>

Setting items	Description
x.v.Color	<p>Set this item when connecting the unit with equipment that supports x.v.Color and playing back an x.v.Color video signal.</p> <p><b>On:</b> You can play back an x.v.Color video signal.</p> <p><b>Off:</b> The “x.v.Color” function is not applied.</p> <p>For details on x.v.Color, see “About x.v.Color” (page 40).</p> <p><b>Tip</b> Setting x.v.Color to “On” disables gamma adjustment.</p>
HDR	<p>Sets how to play back HDR content.</p> <p><b>Auto:</b> Distinguishes HDR content automatically.</p> <p><b>On:</b> Set when playing back HDR content.</p> <p><b>Off:</b> Set when playing back content other than HDR content.</p> <p><b>Note</b> If the setting is not correct for the input content, the bright and dark areas of the video may appear too bright or too dark.</p>
Color Space [COLOR SPACE]	<p>Converts the color space.</p> <p><b>BT.709:</b> An ITU-R BT.709 color space. The color space is equivalent to sRGB.</p> <p><b>BT.2020:</b> The color space is wider than BT.709. Use this setting when playing back HDR content.</p> <p><b>DCI:</b> A color space based on the DCI specification (page 40).</p> <p><b>Adobe RGB:</b> An approximated Adobe RGB color space, which has a wider range of color reproduction than sRGB, and suited for displaying an image recorded in Adobe RGB specification.</p> <p><b>Color Space 1:</b> The color space suited for video images.</p> <p><b>Color Space 2:</b> The color space suited for watching video images in a bright space.</p> <p><b>Color Space 3:</b> The color space suited for watching movies in a bright space.</p> <p><b>Custom 1, Custom 2:</b> You can adjust the color space setting.</p> <div data-bbox="655 895 932 1008" data-label="Image"> </div> <p><b>Tip</b> You can adjust each item to a color space according to your preference.</p>
Input Lag Reduction	<p>Reduces the delay of the display for a video.</p> <p><b>On:</b> Shortens the time to display the input video image; effective for increasing the performance of the display reaction speed when using an external controller, etc.</p> <p><b>Off:</b> Turns the Input Lag Reduction function off.</p> <p><b>Tip</b> When “Input Lag Reduction” is set to “On,” the following items cannot be set: “Combination,” “Smooth High,” and “True Cinema” of “Motionflow”</p>

---

## Advanced Picture Menu

You can adjust the gaps in color that have occurred after a long period of use.

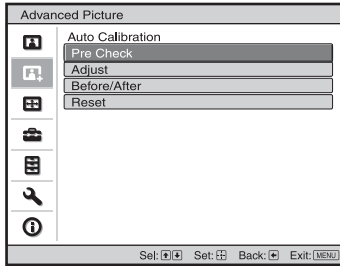

---

Setting items	Description
Auto Calibration	<b>Pre Check:</b> Checks the color difference against the factory default settings, before calibration starts. <b>Adjust:</b> Performs Auto Calibration. <b>Before/After:</b> Toggles the factory default settings and the setting after the calibration at a certain frequency. You can check the effect of the calibration by monitoring the actual image. <b>Reset:</b> Resets the calibration results, and returns to the factory default settings.

---

### Notes

- Auto Calibration results in relatively coarse calibration. The color settings are not guaranteed to be the same as the factory default values.
- The colors are projected automatically while performing “Pre Check” or “Adjust.” A similar phenomenon may occur infrequently while the power is off to adjust the unit. Both cases are not a malfunction.
- Do not turn off the power or operate the remote control or control panel during “Pre Check” or “Adjust,” as the process may be canceled.

### Tips

- dE is an indicator of changing color. The smaller the value of dE, the fewer the changes caused by the color.
- Perform the calibration after the power has been on for more than 30 minutes.
- It takes a few minutes for “Pre Check” or “Adjust” to complete.
- When “Pre Check” or “Adjust” starts, the screen position may shift as the lens returns to its factory default position. After completion, the screen returns to its previous position automatically.
- If the environment, such as the brightness of the room, changes while performing “Pre Check” or “Adjust”, measurement may be affected.
- If the “Pre Check” or “Adjust” function fails, try it again.

# Screen Menu

You can set the picture size, aspect mode, etc.

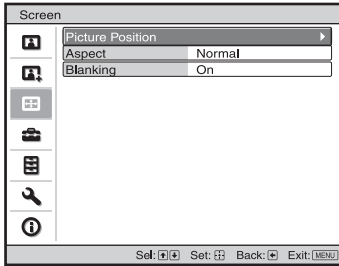







## Note

These items may not be available, depending on the type of input signal. For details, see “Input Signals and Adjustment/Setting Items” (page 43).

Item names in brackets represent those printed on the remote control.

Setting items	Description
Picture Position [POSITION]	<p>You can store up to five combinations of lens settings, aspect ratio, and blanking.</p> <p>After setting the lens, aspect, and blanking, select from “1.85:1,” “2.35:1,” “Custom 1,” “Custom 2,” or “Custom 3” depending on the subtended screen angle, and after confirming, continue by selecting “Save,” “Delete,” or “Select.”</p> <p><b>Save:</b> Stores the current lens settings (focus, window size, window position) in the selected position. If a setting is already stored in that position, it is overwritten.</p> <p><b>Delete:</b> Deletes the stored setting. After the setting is deleted, “1.85:1,” “2.35:1,” “Custom 1,” “Custom 2,” or “Custom 3” in the display change to “---.”</p> <p><b>Select:</b> Recalls the settings of the selected position.</p> <p><b>Tip</b></p> <p>The optimal aspect ratio is preset for each picture position. The aspect ratio can be changed and saved for each picture position.</p> <p><b>Notes</b></p> <ul style="list-style-type: none"><li>• After you have selected and confirmed the lens position, the lens starts to move. Do not touch the lens and the area around the lens, otherwise it may cause injury or a malfunction.</li><li>• If you press any button on the remote control or the unit while the lens is moving, the lens stops. In this case, select the lens position again or adjust the lens manually.</li><li>• When you use a 2.35:1 or a 16:9 subtended angle with the Picture Position function, make sure that the installation position is suitable (page 13).</li><li>• The Picture Position function is not guaranteed to reproduce the lens settings precisely.</li></ul>

Setting items	Description
Aspect [ASPECT]	<p>You can set the aspect ratio of the picture to be displayed for the current input signal (page 14).</p> <p><b>1.85:1 Zoom:</b> A 1.85:1 aspect ratio picture is displayed in its original aspect ratio, enlarged so that black bands do not appear at the top and bottom of the projection surface.</p> <p><b>2.35:1 Zoom:</b> A 2.35:1 aspect ratio picture is displayed in its original aspect ratio, enlarged so that black bands at the top and bottom of the projection surface are as small as possible. When you select “2.35:1 Zoom” from “Trigger Select 1/2” on the Installation  menu, a 12 V signal is output from the TRIGGER 1 or TRIGGER 2 connector (page 31).</p> <p><b>Normal:</b> Input video is displayed in its original aspect ratio, enlarged to fill the projection surface. This mode is suitable for viewing 1.78:1 (16:9) and 1.33:1 (4:3) video.</p> <p><b>V Stretch:</b> This is the most suitable mode for using a 2.35:1 screen to view 2.35:1 video with a commercially available anamorphic lens.</p> <p>When you select “V Stretch” from “Trigger Select 1/2” on the Installation  menu, a 12 V signal is output from the TRIGGER 1 or TRIGGER 2 connector (page 31).</p> <p><b>Squeeze:</b> With this setting, 1.78:1 (16:9) and 1.33:1 (4:3) video will be displayed in their correct aspect ratios when you use a commercially available anamorphic lens.</p> <p><b>Stretch:</b> Displays video that has been squeezed to 1.33:1 (4:3) as 1.78:1 (16:9) aspect ratio.</p> <p><b>Tips</b></p> <ul style="list-style-type: none"> <li>• When you select “V Stretch” or “Squeeze,” select the anamorphic lens type from “Anamorphic Lens” in the Installation  menu.</li> <li>• Selectable aspect modes vary depending on the input signal (page 44).</li> </ul>

Blanking	<p>This feature allows you to adjust the displayable region within the four directions of the screen.</p> <p><b>On:</b> Select the edge to adjust by highlighting Left, Right, Top, or Bottom using the / buttons. Adjust the amount of blanking using the / buttons.</p>
----------	---

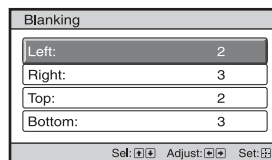

**Off:** Turns off the Blanking function.

**Tip**

Depending on the aspect ratio setting, right/left blanking may not be available.

# Setup Menu

The Setup menu is used to change the factory preset settings, etc.

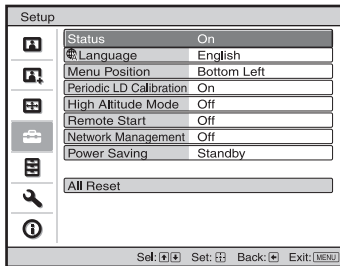

Setting items	Description
Status	<p>Sets whether or not on-screen messages or menus, etc. are displayed.</p> <p><b>On:</b> Displays on-screen messages and menus.</p> <p><b>Off:</b> Turns off the on-screen displays, other than certain menus, a message when turning off the power, and warning messages.</p> <p><b>All Off:</b> Turns off the on-screen displays, other than certain menus, and a message when turning off the power.</p> <p><b>Notes</b></p> <ul style="list-style-type: none"> <li>• When “All Off” is selected, warning message for high temperature is not displayed.</li> <li>• Note that Sony is not liable for failure of the unit or any accident caused by selecting “All Off.”</li> </ul>
Language	<p>Selects the language used in the menu and on-screen displays.</p>
Menu Position	<p>You can change the position to display the menu on the projection surface.</p> <p><b>Bottom Left:</b> Displays the menu on the bottom left area of the projection surface.</p> <p><b>Center:</b> Displays the menu on the center of the projection surface.</p>
Periodic LD Calibration	<p>Performs the calibration automatically after a certain period of use. At that time, the calibration starts when the I/⏻ button of the unit or the ⏻ button of the remote controller is pressed, and after the calibration finishes the power turns off.</p> <p><b>On:</b> Performs the calibration automatically.</p> <p><b>Off:</b> Does not perform the calibration automatically.</p>
High Altitude Mode	<p>Sets the unit to operate at the prevailing atmospheric pressure.</p> <p><b>On:</b> Use this setting when using the unit at an altitude of 1,500 m (approx. 4,900 ft) or higher.</p> <p><b>Off:</b> Use this setting when using the unit at normal altitudes.</p> <p><b>Tip</b></p> <p>When this item is set to “On,” the fan noise becomes slightly louder since the fan speed increases.</p>
Remote Start	<p>Sets the Remote Start settings.</p> <p><b>On:</b> You can turn on the power from a PC or a terminal which is connected to a network.</p> <p><b>Off:</b> Turns off the Remote Start function.</p> <p><b>Tips</b></p> <ul style="list-style-type: none"> <li>• To use the function, the unit should be connected to the network in advance (page 32).</li> <li>• To turn on the power with the Remote Start function, a special command should be sent from a PC or a terminal. For details, consult with qualified Sony personnel.</li> </ul> <p><b>Note</b></p> <p>When the Remote Start is set to “On,” the standby power requirement will increase. When Network Management is set to “On,” Remote Start is fixed at “On” and is not displayed in the menu.</p>
Network Management	<p><b>On:</b> Set when connected to the network and continuously communicating with the projector control equipment.</p> <p><b>Off:</b> Turns off the Network Management function.</p> <p><b>Note</b></p> <p>When Network Management is set to “On,” the network function is continuously enabled. Set Network Management to “Off” for normal use. If you set to “On,” the power consumption increases.</p>

---

<b>Setting items</b>	<b>Description</b>
Power Saving	Sets the Power Saving mode. <b>Standby:</b> If no signal is input for 10 minutes, power is turned off automatically and the projector goes into standby mode. <b>Off:</b> Disables the Power Saving function.
All Reset	All settings are initialized to their factory preset values.

---

# Function Menu

The Function menu is used for changing the settings of the various functions of the unit.

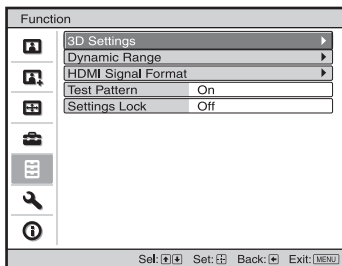

Setting items	Description
3D Settings	You can change the settings of the 3D function.
2D-3D Display Sel.	<p>For Switching the video images to “2D” or “3D.”</p> <p><b>Auto:</b> Displays 3D video images when HDMI signals with 3D information* are input. Displays 2D video images when other signals are input.</p> <p><b>3D:</b> Displays 3D video images according to the 3D system selected in “3D Format.” However, when HDMI signals with 3D information are input to the unit, displays 3D video images according to the 3D system of those HDMI signals.</p> <p><b>3D Format:</b> Set the 3D system when the input HDMI signals do not include 3D information.</p> <p><b>Simulated 3D:</b> Converts 2D video images to 3D video images. The setting can be made only for input the HD signals.</p> <p>The simulated 3D feature may have limited effect, depending on the video source.</p> <p>There are differences in perception of 3D video images among individuals.</p> <p><b>Side-by-Side:</b> Select this to display 3D images as two similar images, side-by-side.</p> <p><b>Over-Under:</b> Select this to display 3D images as two similar images, one above the other.</p> <p><b>Tips</b></p> <ul style="list-style-type: none"> <li>• “2D-3D Display Sel.” cannot be set to “3D” for some video sources. For available 3D signals, see “Compatible 3D Signals” (page 43).</li> <li>• The simulated 3D feature may have limited effect, depending on the projection image size (100 to 120 inches recommended) and the video source.</li> <li>• The menu display has a ghost while a 3D video image is displayed and is best viewed with the 3D glasses.</li> </ul>
3D Brightness	For adjusting the brightness of the picture when watching 3D video images. You can select the brightness from “High” or “Standard.”
3D Depth Adjust	<p>For adjusting the depth of the 3D video images on the projection surface. The setting can be made only when a 3D Format other than “Simulated 3D” is selected.</p> <p style="text-align: center;">Depth -2 -1 0 +1 +2 Front ← Normal → Depth</p> <p>We recommend that “3D Depth Adjust” be set to “0.” The 3D video images may be difficult to perceive, depending on the setting of “3D Depth Adjust.”</p>
Simulated 3D Effect	<p>For adjusting the 3D effect when 2D content is converted to 3D video images. You can select the effect from among “High,” “Middle,” and “Low.”</p> <p><b>Tip</b></p> <p>There are differences in perception of 3D video images converted by the simulated 3D function among individuals.</p>
Dynamic Range	<p>Sets the video input level for HDMI 1 and HDMI 2 connectors.</p> <p><b>Auto:</b> Sets the video input level automatically.</p> <p><b>Limited:</b> The video input level is set for signals of 16-235.</p> <p><b>Full:</b> The video input level is set for signals of 0-255.</p> <p><b>Note</b></p> <p>If the video output setting of the connected HDMI device is not set correctly, light and dark parts of the video may appear too light or too dark.</p>

Setting items	Description
HDMI Signal Format	<p>Switches the video signal formats for 4K.</p> <p><b>Standard Format:</b> Select this format if the projector cannot display the 4K video properly.</p> <p><b>Enhanced Format:</b> This format is the factory default setting. Video has a higher definition when compared with Standard Format.</p>
Test Pattern	<p>Displays a test pattern according to the setting.</p> <p><b>On:</b> A test pattern appears on the screen to be used when adjusting the lens with “Lens Focus,” “Lens Zoom,” and “Lens Shift.”</p> <p><b>Off:</b> A test pattern does not appear.</p> <p><b>Tip</b> While the test pattern is displayed, it is only displayed in green to allow you to adjust the focus easily.</p>
Settings Lock	<p>Locks menu item settings to prevent operational error (page 30).</p> <p><b>Off:</b> Cancels the Settings Lock.</p> <p><b>Level A:</b> Group 1 items (below) are not displayed on the menu, and are not available.</p> <p><b>Level B:</b> Group 1 and Group 2 items (below) are not displayed on the menus, and are not available.</p>

## Items Locked by Settings Lock

### Group 1

---

#### Picture menu

---

Reset  
Reality Creation  
Laser Light Setting  
Contrast Enhancer  
Motionflow  
Contrast  
Brightness  
Color  
Hue  
Color Temp.  
Sharpness  
NR  
MPEG NR  
Smooth Gradation  
Film Mode  
Gamma Correction  
Color Correction  
Clear White  
x.v.Color  
HDR  
Color Space

---

#### Advanced Picture menu

---

Auto Calibration

---

#### Setup menu

---

Periodic LD Calibration

---

### Group 2

---

#### Setup menu

---

Status  
Language  
Menu Position  
High Altitude Mode  
Remote Start  
Network Management  
Power Saving

---

#### Function menu

---

Dynamic Range  
Test Pattern

---

#### Installation menu

---

Image Flip  
Lens Control  
Anamorphic Lens  
Trigger Select  
IR Receiver  
Panel Alignment  
Network Setting

---

# 🔧 Installation Menu

The Installation menu is used for changing the installation settings.

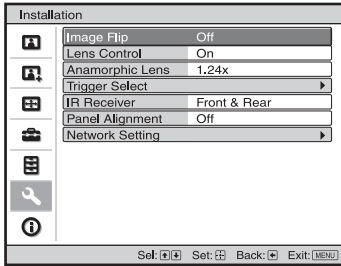

Setting items	Description
Image Flip	Flips the picture on the screen horizontally and/or vertically. <b>HV:</b> Flips the picture horizontally and vertically. <b>H:</b> Flips the picture horizontally. <b>V:</b> Flips the picture vertically. <b>Off:</b> The picture does not flip. Use this item for installation for the rear projection or ceiling installation.
Lens Control	Avoids any operation of the lens such as “Lens Focus,” “Lens Zoom,” and “Lens Shift,” by mistake. <b>On:</b> Enables adjustment of the lens. <b>Off:</b> Prevents any adjustment of the lens.
Anamorphic Lens	Select a setting to match the anamorphic lens conversion ratio. <b>1.24x:</b> Select this when you use an anamorphic lens with a horizontal rate of 1.24x. <b>1.32x:</b> Select this when you use an anamorphic lens with a horizontal rate of 1.32x.
Trigger Select	Switches the output function of the TRIGGER 1/TRIGGER 2 connector. <b>Off:</b> Turns off the TRIGGER connector function. <b>Power:</b> Outputs 12 V signals from the TRIGGER 1/TRIGGER 2 connectors when the unit is on. The TRIGGER 1/TRIGGER 2 connectors do not output any signals when the unit is in standby. <b>V Stretch:</b> Works with the “Aspect” setting’s “V Stretch” (page 25) and outputs a 12 V signal from the TRIGGER 1 or TRIGGER 2 connector. <b>2.35:1 Zoom:</b> Works with the “Aspect” setting’s “2.35:1 Zoom” (page 25) and outputs a 12 V signal from the TRIGGER 1 or TRIGGER 2 connector. <b>3D:</b> Outputs a 12 V signal from the TRIGGER 1 or TRIGGER 2 connector when the 3D signal is input or when working with “2D-3D Display Sel.” of “3D” “3D Settings” (page 28).
IR Receiver	Selects the remote control detectors (IR Receiver) on the front and rear of the unit. <b>Front &amp; Rear:</b> Activates both the front and rear detectors. <b>Front:</b> Activates the front detector only. <b>Rear:</b> Activates the rear detector only.

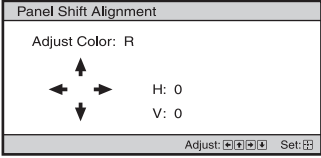
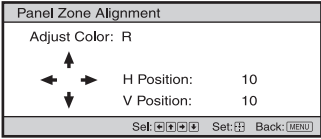
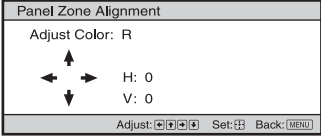
Setting items	Description
Panel Alignment	<p>This feature allows you to adjust the gaps in the color of characters or the picture on the projection surface.</p> <p><b>On:</b> Adjusts the gaps in the colors selecting “Adjust Item” or “Adjust Color.”</p> <p><b>Adjust Item:</b> Selects how to make adjustments from below.</p> <p><b>Shift:</b> Shifts the whole picture and makes adjustments.</p> <p><b>Zone:</b> Selects the desired range and makes adjustments.</p> <p><b>Adjust Color:</b> Assigns the desired color to adjust the gaps in color. Select “R” (Red) or “B” (Blue) to make adjustments based on “G” (Green).</p> <p><b>Pattern Color:</b> Select “R/G” (Red and Green) or “R/G/B” (White, all colors) when “Adjust Color” is “R” (Red). Select “B/G” (Blue and Green) or “R/G/B” (White, all colors) when the “Adjust Color” is “B” (Blue).</p> <p><b>Adjust:</b> The shift adjustment and zone adjustment of the color selected in “Adjust Color” can be made with the ←/→, ↑/↓ buttons.</p> <p>When “Shift” is selected: Assign the settings of the horizontal direction (H) with the ←/→ buttons and the vertical direction (V) with the ↑/↓ buttons on the shift adjustment screen.</p>
	
	<p>When “Zone” is selected: Select the position to adjust with the ←/→ buttons for the horizontal position (H Position) and the ↑/↓ buttons for the vertical position (V Position), then press Ⓢ.</p>
	
	<p>Set the amount to adjust with the ←/→ buttons for the horizontal direction (H) and with the ↑/↓ buttons for the vertical direction (V). You can select the position to adjust again by pressing Ⓢ.</p>
	
	<p><b>Reset:</b> Returns to the factory settings.</p> <p><b>Off:</b> The optimized data has been preset.</p>
	<p><b>Note</b></p> <p>Depending on the adjustments made above, colors may become uneven or the resolution may change.</p>
Network Setting	Perform internet protocol settings.
IPv4 Setting	<p><b>IP Address Setup:</b> Selects the IP address setting method.</p> <p><b>Auto(DHCP):</b> The IP address is assigned automatically from the DHCP server such as a router.</p> <p><b>Manual:</b> Specifies the IP address manually.</p> <p>When “Manual” is selected for “IP Address Setup,” select the item with the ←/→ buttons and input the value with the ↑/↓ buttons. When all items are entered, select “Apply,” and then press the Ⓢ button. The entered settings will be registered.</p> <p><b>IP Address:</b> Sets the unit’s IP address.</p> <p><b>Subnet Mask:</b> Sets the unit’s subnet mask.</p> <p><b>Default Gateway:</b> Sets the unit’s default gateway.</p> <p><b>MAC Address:</b> Displays the unit’s MAC address. This cannot be changed.</p> <p><b>Apply:</b> Enables the IP address that is set manually.</p>
IPv6 Information	<p>Displays the IPv6 information.</p> <p>When you set the IPv6 IP address, set it on a Web browser (page 34).</p>

# Information Menu

The Information menu displays the model name, serial number, input signal type, and software version.

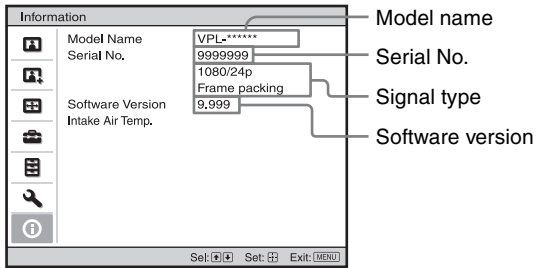

Items	Description
Model Name	Displays the model name
Serial No.	Displays the serial number.
Signal type	Displays the preset memory number and resolution of the video which you are watching. When input signals with 3D information are input, the type of input signals and the 3D format are displayed.
Software Version	Displays the software version.
Intake Air Temp.	Displays the intake air temperature.

## Note

You cannot adjust or change the displays listed above.

## About the Preset Memory

This unit has default image data to adjust preset data for input signals appropriately according to the signals shown in “Preset Signals” (page 42) (the preset memory). When the preset signal is input, the unit automatically detects the signal type and recalls the data for the signal from the preset memory to adjust it to an optimum picture. The signal type is displayed in the Information  menu.

## Note

Depending on the computer input signal, parts of projection image may be hidden or displayed incorrectly.

# Using Network Features

Connection to the network allows you to operate the following features:

- Checking the current status of the unit via a Web browser.
- Making the network settings for the unit.
- Network monitoring and controlling with control protocol (SDAP [Advertisement], SDCP [PJ Talk], DDDP [AMX], Crestron RoomView, Control4).

## Notes

- When connecting this projector with the network, consult with the network administrator. The network must be secured.
- When using this projector connected with the network, access the Control window via a Web browser and change the access limitation of the factory preset values (page 35). It is recommended to change the password regularly.
- When the setting on the Web browser is completed, close the Web browser to log out.
- The menu displays used for the explanation below may be different depending on the model you are using.
- Supported Web browsers are Internet Explorer 8/9/10/11.
- The menu displays only English.
- If the browser of your computer is set to [Use a proxy server] when you have access to the unit from your computer, click the check mark to set accessing without using a proxy server.
- AMX DDDP is not compatible with IPv6.
- These network functions are available when the unit is turned on.

`http://xxx.xxx.xxx.xxx`

(xxx.xxx.xxx.xxx: IP address for the unit)

## When connecting by the IPv6 address

`http://[xxxx:xxxx:-xxxx]`

You can confirm the IP address of the unit under “Network Setting” on the Installation  menu.

The following window appears in the Web browser:

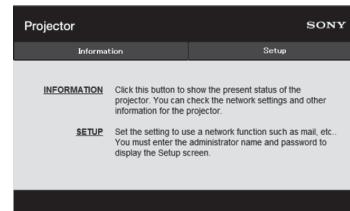

Once you make the network settings, you can open the Control window only by performing step **3** of this procedure.

## Displaying the Control Window of the Unit with a Web Browser

- 1** Connect the LAN cable.

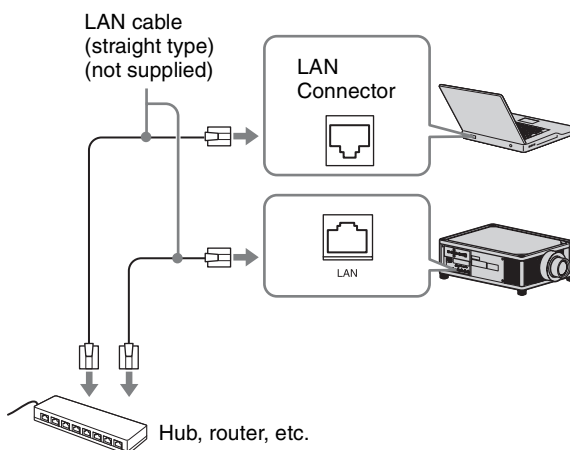

- 2** Set the network settings for the unit using “Network Setting” on the Installation  menu (page 32).
- 3** Start a Web browser on the computer, enter the following in the address field, then press the Enter key on your computer.

# Operating the Control Window

## Switching the Page

Click one of the Page Switching buttons to display the desired setting page.

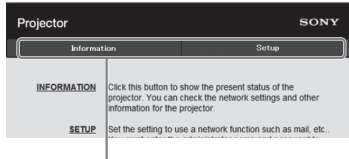

Page Switching buttons

## Setting the Access Limitation

You can limit a user for accessing any particular page.

**Administrator:** Allowed access to all pages

**User:** Allowed access to all pages except the Setup page

When you access the Setup page for the first time, input “root” as the user name and “Projector” as the password in the authentication dialog.

When you log in for the first time, the window that prompts you to change the password is displayed. Follow the instructions on the screen to change the password.

The name of the administrator is preset to “root.”

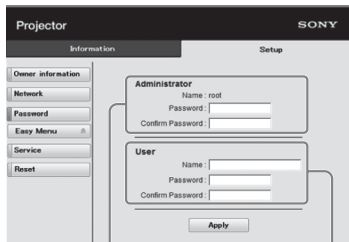

Entry area for [Administrator]

Entry area for [User]

The password can be changed in the Password page in the Setup page.

When you change the password, input a new password after deleting the password (\*\*\*\*\*) that was set.

The password of the administrator and user should be 8 to 16 characters that includes both alphabet and numeric characters. Alphabet is case-sensitive.

The default password “Projector” cannot be set as a new password.

### Note

If you forget your password, consult with qualified Sony personnel.

## Confirming the Information Regarding the Unit

You can confirm the current settings for the unit on the Information page.



Information area

# Error Handling



## Troubleshooting

If the unit appears to be operating erratically, try to diagnose and correct the problem using the following instructions. If the problem persists, consult with qualified Sony personnel.

### Power

Symptom	Cause and Remedy	Page
The power is not turned on.	Check the indicators.	38
	After the AC power cord is connected, it may take about 10 seconds until the unit is ready to be turned on. Wait a while then turn on the unit.	–
The power is suddenly turned off.	Check that “Power Saving” in the Setup  menu is set to “Standby.”	27
	Set “Power Saving” to “Off.”	27

### Picture

Symptom	Cause and Remedy	Page
No picture.	Check that the connecting cable is connected to the external equipment properly.	10
	Select the input source correctly using the INPUT button.	12
	Check that the computer signal is set for output to an external monitor. If a notebook computer and the signal is output to its display and an external monitor, the external monitor’s image may not be displayed correctly. Set your computer to output the signal to only an external monitor.	–
The picture has ghosts.	Video images are displayed in 3D. Watch the 3D video images using the 3D glasses, and set “2D-3D Display Sel.” to “3D.”	12, 28
Bright or dark area of the video appears too bright or too dark.	This symptom may occur when a signal level other than those of HDMI standard is input. Switch the output level of the connected equipment, or switch the Dynamic Range on the Function  menu of the unit.	28
The picture is too dark.	Adjust “Contrast” or “Brightness” on the Picture  menu properly.	20
The picture is not clear.	Adjust the focus.	7
	Condensation has accumulated on the lens. Leave the unit for about two hours with the power on.	–
The color of characters or the picture is not appropriate.	Select the desired color registration in “Panel Alignment” on the Installation  menu.	32
Image is left on the projection image. (Image retention)	When high contrast non-moving images are displayed for a long period of time, there may be some image retention on the projection image. This is only a temporary condition. Turning off the power for a while will eliminate the retained image.	–

### On-screen display

Symptom	Cause and Remedy	Page
On-screen display does not appear.	Set “Status” on the Setup  menu to “On.”	26
	Check if the ON/STANDBY indicator should light in green. When the ON/STANDBY indicator blinks in green, the unit is starting up. Wait until it stops blinking and remains lit in green.	7

## Remote control

Symptom	Cause and Remedy	Page
The remote control does not work.	Batteries could be weak. Replace them with new batteries.	–
	Insert the batteries with the correct polarities.	–
	If there is a light source near the remote control detector, the unit may work improperly or inadvertently.	–
	Confirm the position of the remote control detector on the unit.	4
	Set “IR Receiver” to “Front & Rear” on the Installation  menu.	31
	Make sure that the cable is not connected to the IR IN connector.	3

## 3D video images

Symptom	Cause and Remedy	Page
The video image does not seem like 3D video images.	Check if the 3D glasses are turned on.	12
	Make sure that the battery in the 3D glasses is sufficiently charged.	–
	Set “2D-3D Display Sel.” to “Auto” or “3D.”	28
	Check if the input signals are compatible 3D signals.	43
	The 3D signals may not be input depending on the specifications of the connected AV selector/AV amplifier/external equipment. If the 3D signal is not input, confirm the specifications and/or settings of the AV selector/AV amplifier/external equipment.	–
	When the viewing position is too far from the unit, the 3D glasses may not be able to display the images properly.	13
	The projection image size is not appropriate. Set the zooming magnification to low or watch the image from farther away from the projection surface.	46
	For details, see “Precautions for use” of “Using the 3D Glasses.”	13

## Others

Symptom	Cause and Remedy	Page
The fan is noisy.	Check the setting of “High Altitude Mode” on the Setup  menu.	26
	Make sure that the room temperature is not too high.	–
	Check the installation requirements of the unit. Fan speed increases to maintain the product reliability of the projector’s components in a room where the temperature is higher than normal. The fan noise becomes slightly louder in these rooms. The approximate normal temperature for the unit is 25°C (77°F).	–
The lens shift cannot be adjusted.	The lens shift cannot be adjusted over the range of movement. Adjust the lens shift within the range of movement.	8, 46

# About Indicators

The ON/STANDBY or WARNING indicator lights up or flashes if there is any trouble with your projector.

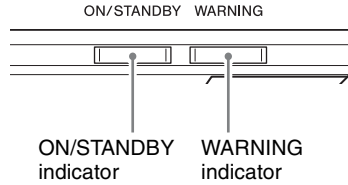

Flashing/Lighting indicators	The number of flashes	Cause and Remedy
	Three times	The temperature of the light source is unusually high. Turn off the power and wait for the light source to cool, then turn on the power again. If the symptom persists, the light source may be at the end of its service life. In this case, consult with qualified Sony personnel.
<p>(Flashes in red)</p>	Six times	The unit detects a drop impact. If there is abnormality on the unit, consult with qualified Sony personnel. If there are no abnormalities on the unit, disconnect the AC power cord and check that the ON/STANDBY indicator turns off, then connect the AC power cord and turn the unit on.
	Eight times	The lens is not securely attached.
<p>(Flashes in red) (Flashes in red) Both indicators flash</p>	Twice	The internal temperature is unusually high. Check to ensure that nothing is blocking the ventilation holes and the unit is not being used at high altitudes.

## Note

If the indicator starts flashing in a way of other than the above, and the symptom persists even after carrying out the above methods, consult with qualified Sony personnel.

# Message Lists

## Warning messages

Symptom	Cause and Remedy	Page
High temp.! Light off in 1 min.	Turn off the power. Check to ensure that nothing is blocking the ventilation holes.	– 4
Frequency is out of range!	Frequency is out of range. Input a signal that is within the acceptable frequency range of the unit.	42
Projector temperature is high. High Altitude Mode should be “On” if Projector is being used at high altitude.	Check to ensure that nothing is blocking the ventilation holes.	4
	When using the unit at high altitude, set “High Altitude Mode” to “On.” <b>Note</b> When temperature inside the unit remains high, “High Altitude Mode” is switched to “On” in 1 minute, then the fan speed increases.	26
Power Saving Mode is set. Projector will automatically enter Standby Mode in 1 minute.	“Power Saving” is set to “Standby.” <b>Note</b> If no signal is input, the power turns off after 1 minute, and the projector goes into standby mode.	27

## Caution messages

Symptom	Cause and Remedy	Page
x→	No signal is input in the selected input. Check connections.	10
Not applicable!	Press the appropriate button. The operation to be activated by the button is currently prohibited.	–
Settings Lock enabled.	“Settings Lock” is set to “Level A” or “Level B.”	29

---

## Updating the Software

You can download files to update the software of the unit. Copy the downloaded files to your USB memory, insert the USB memory to the USB terminal of the unit, then perform the update.

To use the features updated, insert a USB memory device into a PC connected to the internet.

Download the update files from the following Sony website:

<http://www.pro.sony.eu/>

The website also explains how to install the update.

### Note

Some USB memories may not be supported for use. For details, refer to the website above.

---

## About HDR (high dynamic range)

HDR is a video expression which improves the ability to express dark places and bright places compared to previous video expressions.

---

## About DCI specification

DCI is a specification for Digital cinema projection systems, established by the industry standards body DCI (Digital Cinema Initiatives), an affiliation of six major Hollywood studios.

---

## About x.v.Color

- “x.v.Color” is a promotion name given to the products that have the capability to realize a wide color space based on the xvYCC specifications and is a trademark of Sony Corporation.
- xvYCC is an international standard of the technical specifications of the extended-gamut color space for video signals. The color gamut of xvYCC is wider than the one of sRGB that is used with the current television system.

---

## About the Simulated 3D Feature

- Use the simulated 3D function taking into account that the picture will provide a different look from the original images, because this function converts the video images.
- Note that if the unit is used for profit or for public viewing, displaying 2D video images as 3D video images by converting to the simulated 3D may constitute an infringement of the rights of authors or producers, which are legally protected.

### Trademark Information

- “PlayStation” is a registered trademark of Sony Computer Entertainment Inc.
- This unit incorporates High-Definition Multimedia Interface (HDMI<sup>®</sup>) technology. The terms HDMI and HDMI High-Definition Multimedia Interface, and the HDMI Logo are trademarks or registered trademarks of HDMI Licensing LLC in the United States and other countries.
- “Blu-ray” and “Blu-ray Disc” are trademarks of Blu-ray Disc Association.

.....  
This projector supports DeepColor, x.v.Color, LipSync, computer input signal, 3D signal, 4K signal (60P 4:4:4) and HDR of HDMI standards. It also supports HDCP.

# Specifications

Item	Description	
Display System	Projection system	
Display device	Size of effective display area	SXRD 0.74-inch (18.8 mm) × 3
	Number of pixels	4096 × 2160 × 3 pixels
Projection lens	Motorized Lens (VPLL-Z7013) Throw Ratio 1.27:1 to 2.73:1 F2.9 to F3.9 Shift: ±80% (V), ±31% (H)	
Projection image size	60-inch to 300-inch (1,524 mm to 7,620 mm)	
Light source	Laser diode	
Accepted digital signals	See “Preset Signals” (page 42).	
Inputs/Outputs	HDMI connectors (HDCP 2.2)	× 2
	REMOTE connector	RS-232C, D-sub 9-pin
	LAN connector	RJ45, 10BASE-T/100BASE-TX
	USB connector	Type A, DC 5 V, Max. 500 mA
	IR connectors	IN: 1, OUT:1, mini jack
	TRIGGER connectors	× 2, mini jack, DC 12 V, Max. 100 mA
Outside dimensions (w/h/d)	550 mm × 228 mm × 750 mm (21 <sup>21</sup> / <sub>32</sub> inches × 8 <sup>31</sup> / <sub>32</sub> inches × 29 <sup>17</sup> / <sub>32</sub> inches)	
Mass	Approx. 43 kg (95 lb) (including the lens)	
Power requirements	AC 220 V to 240 V, 6 A, 50/60 Hz (for Europe and China) AC 100 V to 240 V, 12 A to 6 A, 50/60 Hz (for countries other than Europe and China)	
Power consumption	1.2 kw (max.)	
Standby mode power consumption	(Standby)	0.4 W (when “Remote Start” is set to “Off”)
	(Networked Standby)	0.6 W (LAN) (when “Remote Start” is set to “On”)
Operating temperature (Operating humidity)	5°C to 40°C (41°F to 104°F) (20% to 80% (no condensation))	
Storage temperature (Storage humidity)	–10°C to +60°C (14°F to 140°F) (20% to 80% (no condensation))	
Supplied accessories	See “Checking the Supplied Accessories” on the Quick Reference Manual.	
Optional accessories	Active 3D Glasses: TDG-BT500A*	
	Projection Lens VPLL-Z7008: Motorized, Throw ratio: 0.80:1 to 1.02:1, Shift: ±50% (V), ±18% (H), F2.9, Projected image size: 60" to 1000" (1,524 mm to 25,400 mm), Maximum external dimensions: 134 mm × 131 mm × 309 mm (5 <sup>9</sup> / <sub>32</sub> inches × 5 <sup>5</sup> / <sub>32</sub> inches × 12 <sup>5</sup> / <sub>32</sub> inches) (W × H × D), Mass: 3.7 kg (8.2 lb)	

\* The 3D Glasses communicate with the projector via Bluetooth technology to display 3D signals.

## Notes

- The values for mass and dimensions are approximate.
- Not all optional accessories are available in all countries and area. Please check with your local Sony Authorized Dealer.
- Information on accessories in this manual is current as of February 2016.

Design and specifications of this unit and its optional accessories are subject to change without notice.

## Preset Signals

The following table shows the signals and video formats which you can project using this unit.  
When a signal other than the preset signals shown below is input, the picture may not be displayed properly.

Preset memory no.	Preset signal (resolution)		fH (kHz)	fV (Hz)	Sync
5	480/60p	480/60p (Progressive NTSC) (720 × 480p)	31.470	60.000	–
6	576/50p	576/50p (Progressive PAL) (720 × 576p)	31.250	50.000	–
7	1080/60i	1035/60i (1920 × 1035i) 1080/60i (1920 × 1080i)	33.750	60.000	–
8	1080/50i	1080/50i (1920 × 1080i)	28.130	50.000	–
10	720/60p	720/60p (1280 × 720p)	45.000	60.000	–
11	720/50p	720/50p (1280 × 720p)	37.500	50.000	–
12	1080/60p	1080/60p (1920 × 1080p)	67.500	60.000	–
13	1080/50p	1080/50p (1920 × 1080p)	56.260	50.000	–
14	1080/24p	1080/24p (1920 × 1080p)	26.973	23.976	–
18	720/60p (Frame packing)	720/60p (1280 × 720/60p)	90.000	60.000	–
19	720/50p (Frame packing)	720/50p (1280 × 720/50p)	75.000	50.000	–
20	1080/24p (Frame packing)	1080/24p (1920 × 1080/24p)	53.946	23.976	–
26	640 × 480	VGA	31.469	59.940	H-Neg, V-Neg
32	800 × 600	SVGA	37.879	60.317	H-Pos, V-Pos
37	1024 × 768	XGA	48.363	60.004	H-Neg, V-Neg
45	1280 × 960	QVGA	60.000	60.000	H-Pos, V-Pos
47	1280 × 1024	SXGA	63.974	60.013	H-Pos, V-Pos
55	1280 × 768	WXGA	47.776	59.870	H-Neg, V-Pos
71	1080/60i (Frame packing)	1080/60i (1920 × 1080/60i)	67.500	60.000	–
72	1080/50i (Frame packing)	1080/50i (1920 × 1080/50i)	56.250	50.000	–
74	3840 × 2160/60p	3840 × 2160/60p (3840 × 2160)	133.293	59.988	–
75	3840 × 2160/50p	3840 × 2160/50p (3840 × 2160)	112.500	50.000	–
76	4096 × 2160/60p	4096 × 2160/60p (4096 × 2160)	133.264	59.975	–
77	4096 × 2160/50p	4096 × 2160/50p (4096 × 2160)	112.500	50.000	–
93	3840 × 2160/24p	3840 × 2160/24p (3840 × 2160)	53.946	23.976	–
96	4096 × 2160/24p	4096 × 2160/24p (4096 × 2160)	54	24	–

## Input Signals and Adjustment/Setting Items

The items in the menus available to adjust differ depending on the input signal. The following tables indicate them. The items that cannot be adjusted/set are not displayed in the menu.

### Screen menu

Item	Preset memory number	
	5 to 8, 10 to 14, 18 to 20, 71, 72, 93, 96	26, 32, 37, 45, 47, 55
Aspect	●	–

●: Can be adjusted/set

–: Cannot be adjusted/set

## Compatible 3D Signals

This unit accepts the following types of 3D signals.

Resolution	3D signal format
720/60p, 720/50p	Side-by-Side format
	Over-Under format
	Frame packing
1080/60i, 1080/50i	Side-by-Side format
	Frame packing
1080/24P	Side-by-Side format
	Over-Under format
	Frame packing
1080/60p, 1080/50p	Side-by-Side format
	Over-Under format

## Aspect Mode

Selectable items vary depending on the type of input signal or 3D format.  
For details, see the tables below. Items that cannot be selected are not displayed in the menu.

### 2D

Acceptable signals	4096 × 2160	3840 × 2160	1920 × 1080	1280 × 720	720 × 480 720 × 576	Others
<b>Preset memory number (page 42)</b>	76, 77, 96	74, 75, 93	7, 8, 12 to 14	10, 11	5, 6	26, 32, 37, 45, 47, 55
1.85:1 Zoom	–	●	●	●	●	–
2.35:1 Zoom	–	●	●	●	●	–
Normal	●*	●	●	●	●	●*
V Stretch	●	●	●	●	●	–
Squeeze	●	●	●	●	●	–
Stretch	–	–	–	–	●	–

\*: Not displayed in the menu as fixed at Normal.

### 3D

Acceptable signals	1920 × 1080, 1280 × 720			
3D format	Side-by-Side	Over-Under	Frame packing	Simulated 3D
<b>Preset memory number (page 42)</b>	7, 8, 10 to 14	10 to 14	18 to 20, 71, 72	7, 8, 10 to 14
1.85:1 Zoom	●	●	●	●
2.35:1 Zoom	●	●	●	●
Normal	●	●	●	●
V Stretch	●	●	●	●
Squeeze	●*	●	●	●
Stretch	–	–	–	–

\*: Squeeze cannot be selected if preset memory number 7, 8, 12 or 13 (page 42) is input.

## Storage Conditions of Adjustment/Setting Items

Each adjustable/setting item is individually stored according to the storage conditions in the following table. For further details, see the tables below.

## Picture menu

Item	Storage conditions
Calib. Preset	For each input connector and preset signal
Reset	For each input connector and Calib. Preset
Reality Creation	
Laser Light Setting	
Contrast Enhancer	
Motionflow	
Contrast	
Brightness	
Color	
Hue	
Color Temp.	
D93 - D55, Custom	
Gain R	
Gain G	
Gain B	
Bias R	
Bias G	
Bias B	
Sharpness	For each input connector and Calib. Preset
NR	
MPEG NR	
Smooth Gradation	
Film Mode	
Gamma Correction	
Color Correction	
Clear White	
x.v.Color	
HDR	
Color Space	
BT.709 - Custom	
Red	For each Color Space
Green	
Blue	
Cyan - Red	
Magenta - Green	
Input Lag Reduction	For each input connector and Calib. Preset

## Screen menu

Item	Storage conditions
Aspect	For each Picture Position
Blanking	

# Projection Distance and Lens Shift Range

The projection distance refers to the distance between the front of the lens and the projected surface.

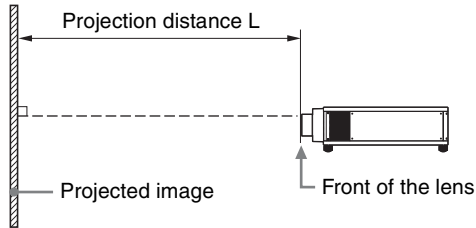

The lens shift range represents the distance in percent (%) by which the lens can be shifted from the center of the projected image. The lens shift range is regarded as 0% when the point **A** in the illustration (point where a line drawn from the center of the lens and the projected image cross at right angles) is aligned with the center of the projected image and full width or full height of the projected image is regarded as 100%.

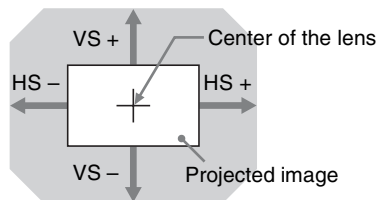
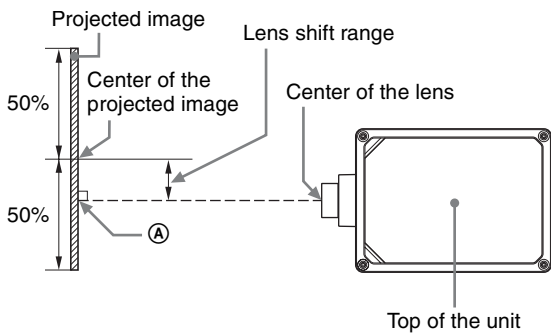
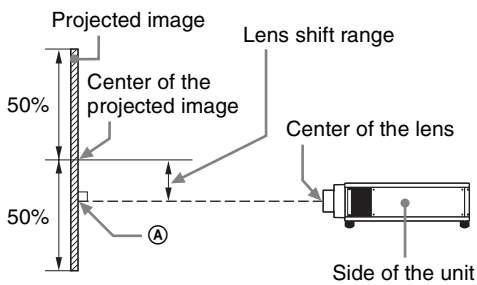

Shaded region: Lens shift range

- VS +: Vertical lens shift range (up) [%]
- VS -: Vertical lens shift range (down) [%]
- HS +: Horizontal lens shift range (right) [%]
- HS -: Horizontal lens shift range (left) [%]

## When projecting in 1.90:1 (Native Full Display 17:9) format

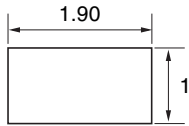

### Projection distance

Unit: m (inches)

Projection image size		Projection distance L	
Diagonal	Width × Height	VPLL-Z7008	VPLL-Z7013
80" (2.03 m)	1.80 × 0.95 (71 × 37)	1.43 – 1.82 (56 – 71)	2.23 – 4.90 (88 – 192)
100" (2.54 m)	2.25 × 1.18 (88 × 47)	1.80 – 2.29 (71 – 90)	2.81 – 6.14 (111 – 241)
120" (3.05 m)	2.70 × 1.42 (106 × 56)	2.17 – 2.76 (86 – 108)	3.39 – 7.38 (134 – 290)
150" (3.81 m)	3.37 × 1.78 (133 × 70)	2.74 – 3.47 (108 – 136)	4.25 – 9.25 (168 – 364)
200" (5.08 m)	4.49 × 2.37 (177 × 93)	3.67 – 4.65 (145 – 183)	5.70 – 12.36 (225 – 486)

### Projection distance formula

D: Projected image size (Diagonal)

Unit: m (inches)

Lens	Projection distance L (minimal length)	Projection distance L (maximal length)
VPLL-Z7008	$L = 0.018689 \times D - 0.0733$ ( $L = 0.735786 \times D - 2.8875$ )	$L = 0.023617 \times D - 0.0664$ ( $L = 0.929788 \times D - 2.6152$ )
VPLL-Z7013	$L = 0.028860 \times D - 0.0800$ ( $L = 1.136218 \times D - 3.1491$ )	$L = 0.062212 \times D - 0.0756$ ( $L = 2.449310 \times D - 2.9775$ )

### Lens shift range

#### VPLL-Z7008

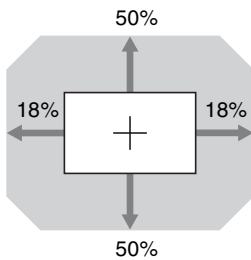

$$VS + = VS - = 50 - 2.778 \times (HS + \text{ or } HS -) [\%]$$

$$HS + = HS - = 18 - 0.360 \times (VS + \text{ or } VS -) [\%]$$

#### VPLL-Z7013

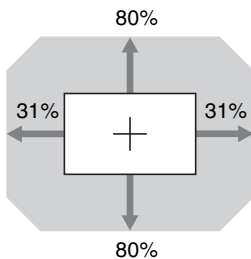

$$VS + = VS - = 80 - 2.581 \times (HS + \text{ or } HS -) [\%]$$

$$HS + = HS - = 31 - 0.388 \times (VS + \text{ or } VS -) [\%]$$

## When projecting in 1.78:1 (16:9) format

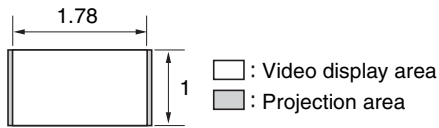

### Projection distance

Unit: m (inches)

Projection image size		Projection distance L	
Diagonal	Width × Height	VPLL-Z7008	VPLL-Z7013
80" (2.03 m)	1.77 × 1.00 (70 × 39)	1.50 – 1.91 (59 – 75)	2.35 – 5.15 (93 – 202)
100" (2.54 m)	2.21 × 1.25 (87 × 49)	1.90 – 2.41 (75 – 95)	2.96 – 6.46 (117 – 254)
120" (3.05 m)	2.66 × 1.49 (105 × 59)	2.29 – 2.91 (90 – 114)	3.56 – 7.77 (141 – 305)
150" (3.81 m)	3.32 × 1.87 (131 × 74)	2.88 – 3.65 (114 – 143)	4.47 – 9.73 (176 – 383)
200" (5.08 m)	4.43 × 2.49 (174 × 98)	3.86 – 4.89 (152 – 192)	5.99 – 13.00 (236 – 511)

### Projection distance formula

D: Projected image size (Diagonal)

Unit: m (inches)

Lens	Projection distance L (minimal length)	Projection distance L (maximal length)
VPLL-Z7008	$L = 0.019643 \times D - 0.0733$ ( $L = 0.773332 \times D - 2.8875$ )	$L = 0.024822 \times D - 0.0664$ ( $L = 0.977234 \times D - 2.6152$ )
VPLL-Z7013	$L = 0.030333 \times D - 0.0800$ ( $L = 1.194198 \times D - 3.1491$ )	$L = 0.065387 \times D - 0.0756$ ( $L = 2.574296 \times D - 2.9775$ )

### Lens shift range

#### VPLL-Z7008

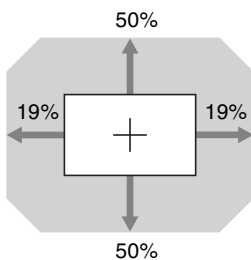

$$VS + = VS - = 50 - 2.632 \times (HS + \text{ or } HS -) [\%]$$

$$HS + = HS - = 19 - 0.380 \times (VS + \text{ or } VS -) [\%]$$

#### VPLL-Z7013

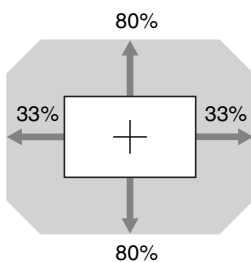

$$VS + = VS - = 80 - 2.424 \times (HS + \text{ or } HS -) [\%]$$

$$HS + = HS - = 33 - 0.413 \times (VS + \text{ or } VS -) [\%]$$

## When projecting in 2.35:1 format

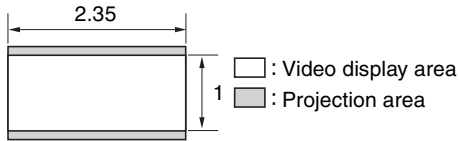

### Projection distance

Unit: m (inches)

Projection image size		Projection distance L	
Diagonal	Width × Height	VPLL-Z7008	VPLL-Z7013
80" (2.03 m)	1.87 × 0.80 (74 × 31)	1.49 – 1.89 (59 – 74)	2.33 – 5.10 (92 – 200)
100" (2.54 m)	2.34 × 0.99 (92 × 39)	1.88 – 2.39 (74 – 94)	2.93 – 6.39 (116 – 251)
120" (3.05 m)	2.80 × 1.19 (110 × 47)	2.26 – 2.88 (89 – 113)	3.53 – 7.69 (139 – 302)
150" (3.81 m)	3.51 × 1.49 (138 × 59)	2.85 – 3.61 (112 – 142)	4.43 – 9.63 (175 – 379)
200" (5.08 m)	4.67 × 1.99 (184 × 78)	3.82 – 4.84 (151 – 190)	5.93 – 12.86 (234 – 506)

### Projection distance formula

D: Projected image size (Diagonal)

Unit: m (inches)

Lens	Projection distance L (minimal length)	Projection distance L (maximal length)
VPLL-Z7008	$L = 0.019441 \times D - 0.0733$ ( $L = 0.765407 \times D - 2.8875$ )	$L = 0.024567 \times D - 0.0664$ ( $L = 0.967219 \times D - 2.6152$ )
VPLL-Z7013	$L = 0.030024 \times D - 0.0800$ ( $L = 1.182064 \times D - 3.1491$ )	$L = 0.064723 \times D - 0.0756$ ( $L = 2.548138 \times D - 2.9775$ )

### Lens shift range

#### VPLL-Z7008

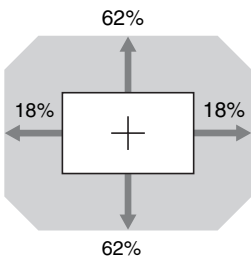

$$VS + = VS - = 62 - 3.444 \times (HS + \text{ or } HS -) [\%]$$

$$HS + = HS - = 18 - 0.290 \times (VS + \text{ or } VS -) [\%]$$

#### VPLL-Z7013

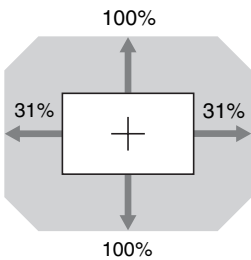

$$VS + = VS - = 100 - 3.226 \times (HS + \text{ or } HS -) [\%]$$

$$HS + = HS - = 31 - 0.310 \times (VS + \text{ or } VS -) [\%]$$

# Dimensions

## Front

Unit: mm (inches)

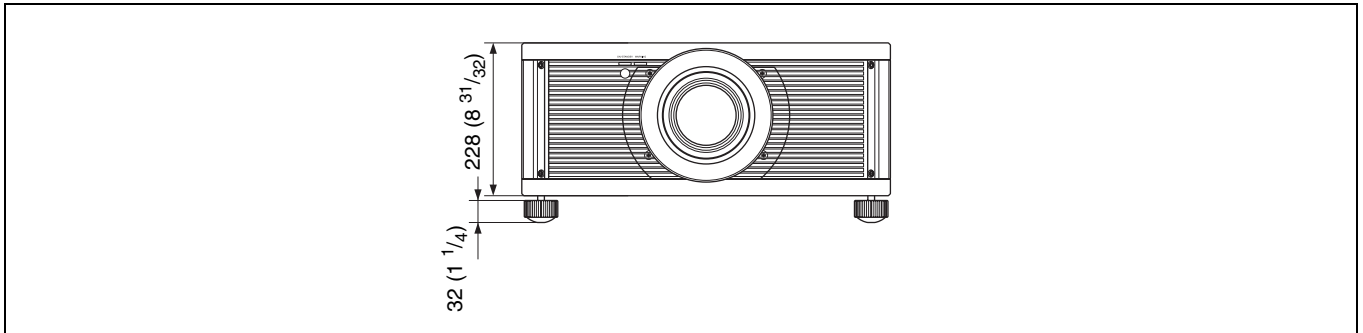

## Top

Unit: mm (inches)

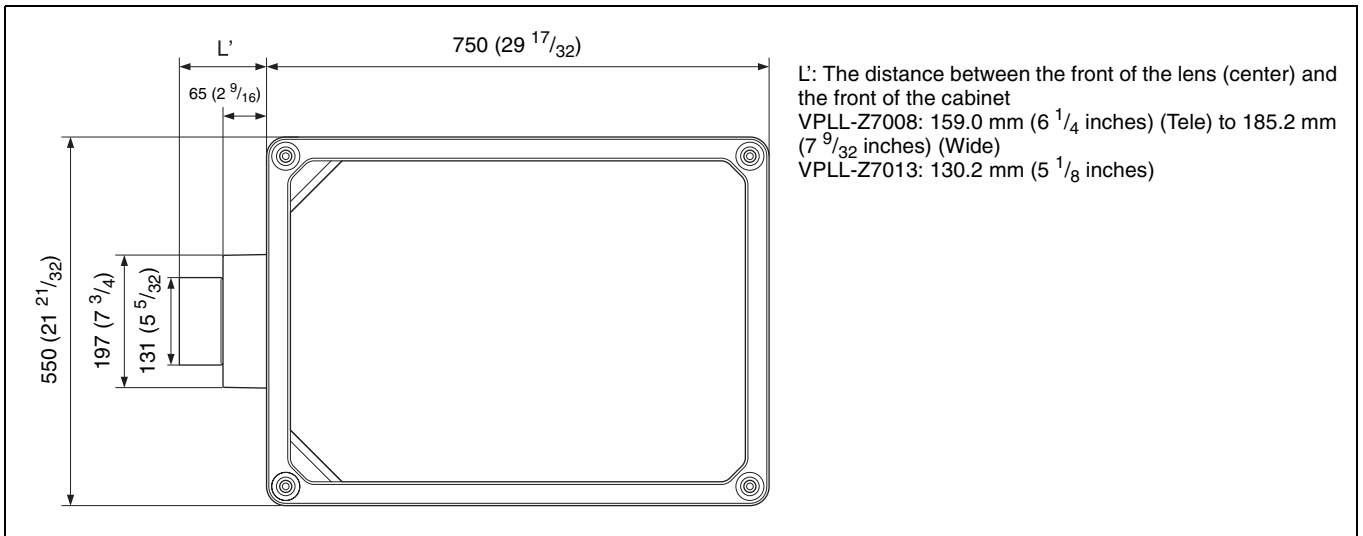

## Bottom

Unit: mm (inches)

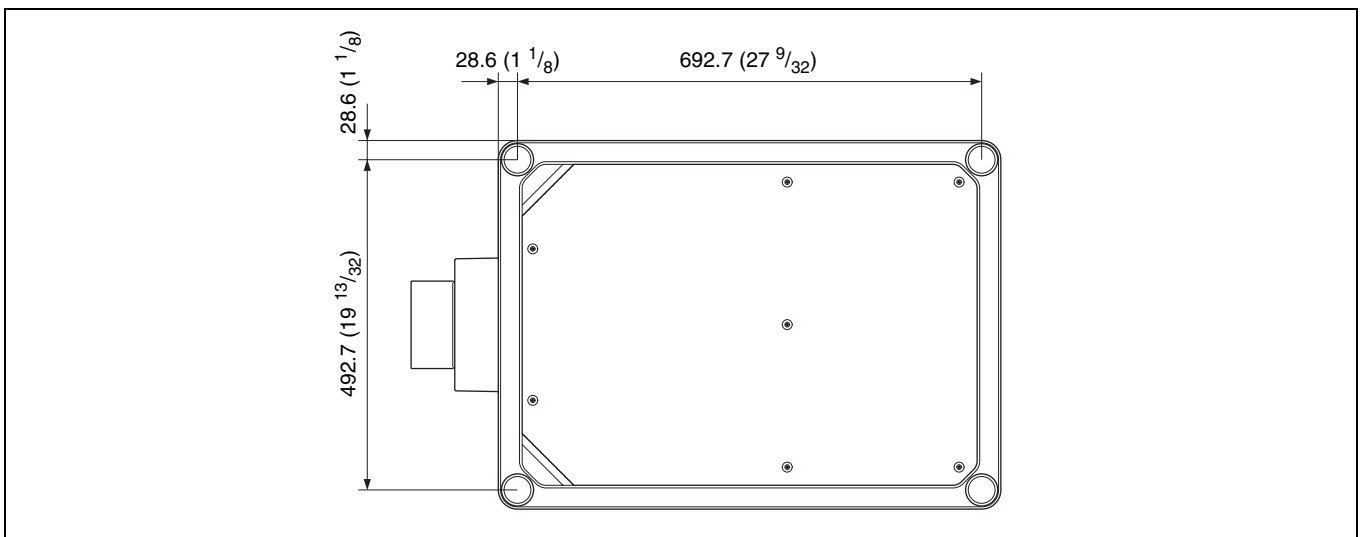

# NOTICES AND LICENCES FOR SOFTWARE USED IN THIS PRODUCT

## GPL/LGPL LICENSED SOFTWARE

The following GPL executables and LGPL libraries are used in this product and are subject to the GPL/LGPL License Agreements included as part of this documentation:

### Package list:

linux-kernel  
alsa-lib  
busybox  
crypto  
directfb  
dosfstools  
e2fsprogs  
exceptionmonitor  
fuse  
gdisk  
glib  
glibc  
iptables  
libmicrohttpd  
libnuma (in numactl)  
procpss  
pump-autoip  
XZ utils

Source code for these executables and libraries, as well as other executables and libraries, can be obtained using the following link:  
<http://oss.sony.net/Products/Linux/>

## GNU GENERAL PUBLIC LICENSE Version 2, June 1991

Copyright (C) 1989, 1991 Free Software Foundation, Inc., 51 Franklin Street, Fifth Floor, Boston, MA 02110-1301, USA. Everyone is permitted to copy and distribute verbatim copies of this license document, but changing it is not allowed.

### Preamble

The licenses for most software are designed to take away your freedom to share and change it. By contrast, the GNU General Public License is intended to guarantee your freedom to share and change free software--to make sure the software is free for all its users. This General Public License applies to most of the Free Software Foundation's software and to any other program whose authors commit to using it. (Some other Free Software Foundation software is covered by the GNU Library General Public License instead.) You can apply it to your programs, too.

When we speak of free software, we are referring to freedom, not price. Our General Public Licenses are designed to make sure that you have the freedom to distribute copies of free software (and charge for this service if you wish), that you receive source code or can get it if you want it, that you can change the software or use pieces of it in new free programs; and that you know you can do these things.

To protect your rights, we need to make restrictions that forbid anyone to deny you these rights or to ask you to surrender the rights. These restrictions translate to certain responsibilities for you if you distribute copies of the software, or if you modify it. For example, if you distribute copies of such a program, whether gratis or for a fee, you must give the recipients all the rights that you have. You must

make sure that they, too, receive or can get the source code. And you must show them these terms so they know their rights.

We protect your rights with two steps: (1) copyright the software, and (2) offer you this license which gives you legal permission to copy, distribute and/or modify the software.

Also, for each author's protection and ours, we want to make certain that everyone understands that there is no warranty for this free software. If the software is modified by someone else and passed on, we want its recipients to know that what they have is not the original, so that any problems introduced by others will not reflect on the original authors' reputations. Finally, any free program is threatened constantly by software patents. We wish to avoid the danger that redistributors of a free program will individually obtain patent licenses, in effect making the program proprietary. To prevent this, we have made it clear that any patent must be licensed for everyone's free use or not licensed at all.

The precise terms and conditions for copying, distribution and modification follow.

## GNU GENERAL PUBLIC LICENSE TERMS AND CONDITIONS FOR COPYING, DISTRIBUTION AND MODIFICATION

**0.** This License applies to any program or other work which contains a notice placed by the copyright holder saying it may be distributed under the terms of this General Public License. The "Program", below, refers to any such program or work, and a "work based on the Program" means either the Program or any derivative work under copyright law: that is to say, a work containing the Program or a portion of it, either verbatim or with modifications and/or translated into another language. (Hereinafter, translation is included without limitation in the term "modification".) Each licensee is addressed as "you".

Activities other than copying, distribution and modification are not covered by this License; they are outside its scope. The act of running the Program is not restricted, and the output from the Program is covered only if its contents constitute a work based on the Program (independent of having been made by running the Program). Whether that is true depends on what the Program does.

**1.** You may copy and distribute verbatim copies of the Program's source code as you receive it, in any medium, provided that you conspicuously and appropriately publish on each copy an appropriate copyright notice and disclaimer of warranty; keep intact all the notices that refer to this License and to the absence of any warranty; and give any other recipients of the Program a copy of this License along with the Program.

You may charge a fee for the physical act of transferring a copy, and you may at your option offer warranty protection in exchange for a fee.

**2.** You may modify your copy or copies of the Program or any portion of it, thus forming a work based on the Program, and copy and distribute such modifications or work under the terms of Section 1 above, provided that you also meet all of these conditions:

**a)** You must cause the modified files to carry prominent notices stating that you changed the files and the date of any change.

**b)** You must cause any work that you distribute or publish, that in whole or in part contains or is derived from the Program or any part thereof, to be licensed as a whole at no charge to all third parties under the terms of this License.

**c)** If the modified program normally reads commands interactively when run, you must cause it, when started running for such interactive use in the most ordinary way, to print or display an announcement including an appropriate copyright notice and a notice that there is no warranty (or else, saying that you provide a warranty) and that users may redistribute the program under these conditions, and telling the user how to view a copy of this License. (Exception: if the Program itself is interactive but does not normally print such an announcement, your work based on the Program is not required to print an announcement.)

These requirements apply to the modified work as a whole. If identifiable sections of that work are not derived from the Program, and can be reasonably considered independent and separate works in themselves, then this License, and its terms, do not apply to those sections when you distribute them as separate works. But when you distribute the same sections as part of a whole which is a work based on the Program, the distribution of the whole must be on the terms of this License, whose permissions for other licensees extend to the entire whole, and thus to each and every part regardless of who wrote it. Thus, it is not the intent of this section to claim rights or contest your rights to work written entirely by you; rather, the intent is to exercise the right to control the distribution of derivative or collective works based on the Program.

In addition, mere aggregation of another work not based on the Program with the Program (or with a work based on the Program) on a volume of a storage or distribution medium does not bring the other work under the scope of this License.

**3.** You may copy and distribute the Program (or a work based on it, under Section 2) in object code or executable form under the terms of Sections 1 and 2 above provided that you also do one of the following:

**a)** Accompany it with the complete corresponding machine-readable source code, which must be distributed under the terms of Sections 1 and 2 above on a medium customarily used for software interchange; or,

**b)** Accompany it with a written offer, valid for at least three years, to give any third party, for a charge no more than your cost of physically performing source distribution, a complete machine-readable copy of the corresponding source code, to be distributed under the terms of Sections 1 and 2 above on a medium customarily used for software interchange; or,

**c)** Accompany it with the information you received as to the offer to distribute corresponding source code. (This alternative is allowed only for noncommercial distribution and only if you received the program in object code or executable form with such an offer, in accord with Subsection b above.) The source code for a work means the preferred form of the work for making modifications to it. For an

executable work, complete source code means all the source code for all modules it contains, plus any associated interface definition files, plus the scripts used to control compilation and installation of the executable. However, as a special exception, the source code distributed need not include anything that is normally distributed (in either source or binary form) with the major components (compiler, kernel, and so on) of the operating system on which the executable runs, unless that component itself accompanies the executable.

If distribution of executable or object code is made by offering access to copy from a designated place, then offering equivalent access to copy the source code from the same place counts as distribution of the source code, even though third parties are not compelled to copy the source along with the object code.

**4.** You may not copy, modify, sublicense, or distribute the Program except as expressly provided under this License. Any attempt otherwise to copy, modify, sublicense or distribute the Program is void, and will automatically terminate your rights under this License.

However, parties who have received copies, or rights, from you under this License will not have their licenses terminated so long as such parties remain in full compliance.

**5.** You are not required to accept this License, since you have not signed it. However, nothing else grants you permission to modify or distribute the Program or its derivative works. These actions are prohibited by law if you do not accept this License. Therefore, by modifying or distributing the Program (or any work based on the Program), you indicate your acceptance of this License to do so, and all its terms and conditions for copying, distributing or modifying the Program or works based on it.

**6.** Each time you redistribute the Program (or any work based on the Program), the recipient automatically receives a license from the original licensor to copy, distribute or modify the Program subject to these terms and conditions. You may not impose any further restrictions on the recipients' exercise of the rights granted herein. You are not responsible for enforcing compliance by third parties to this License.

**7.** If, as a consequence of a court judgment or allegation of patent infringement or for any other reason (not limited to patent issues), conditions are imposed on you (whether by court order, agreement or otherwise) that contradict the conditions of this License, they do not excuse you from the conditions of this License. If you cannot distribute so as to satisfy simultaneously your obligations under this License and any other pertinent obligations, then as a consequence you may not distribute the Program at all. For example, if a patent license would not permit royalty-free redistribution of the Program by all those who receive copies directly or indirectly through you, then the only way you could satisfy both it and this License would be to refrain entirely from distribution of the Program.

If any portion of this section is held invalid or unenforceable under any particular circumstance, the balance of the section is intended to apply and the section as a whole is intended to apply in other circumstances. It is not the purpose of this section to induce you to infringe any patents or other property right claims or to contest validity of any such claims; this section has the sole purpose of protecting the integrity of the free software distribution system, which is implemented by public license practices. Many people have made generous contributions to the wide range of software distributed through that system in reliance on consistent application of that

system; it is up to the author/donor to decide if he or she is willing to distribute software through any other system and a licensee cannot impose that choice.

This section is intended to make thoroughly clear what is believed to be a consequence of the rest of this License.

**8.** If the distribution and/or use of the Program is restricted in certain countries either by patents or by copyrighted interfaces, the original copyright holder who places the Program under this License may add an explicit geographical distribution limitation excluding those countries, so that distribution is permitted only in or among countries not thus excluded. In such case, this License incorporates the limitation as if written in the body of this License.

**9.** The Free Software Foundation may publish revised and/or new versions of the General Public License from time to time. Such new versions will be similar in spirit to the present version, but may differ in detail to address new problems or concerns. Each version is given a distinguishing version number.

If the Program specifies a version number of this License which applies to it and "any later version", you have the option of following the terms and conditions either of that version or of any later version published by the Free Software Foundation. If the Program does not specify a version number of this License, you may choose any version ever published by the Free Software Foundation.

**10.** If you wish to incorporate parts of the Program into other free programs whose distribution conditions are different, write to the author to ask for permission. For software which is copyrighted by the Free Software Foundation, write to the Free Software Foundation; we sometimes make exceptions for this. Our decision will be guided by the two goals of preserving the free status of all derivatives of our free software and of promoting the sharing and reuse of software generally.

## NO WARRANTY

BECAUSE THE PROGRAM IS LICENSED FREE OF CHARGE, THERE IS NO WARRANTY FOR THE PROGRAM, TO THE EXTENT PERMITTED BY APPLICABLE LAW. EXCEPT WHEN OTHERWISE STATED IN WRITING THE COPYRIGHT HOLDERS AND/OR OTHER PARTIES PROVIDE THE PROGRAM "AS IS" WITHOUT WARRANTY OF ANY KIND, EITHER EXPRESSED OR IMPLIED, INCLUDING, BUT NOT LIMITED TO, THE IMPLIED WARRANTIES OF MERCHANTABILITY AND FITNESS FOR A PARTICULAR PURPOSE. THE ENTIRE RISK AS TO THE QUALITY AND PERFORMANCE OF THE PROGRAM IS WITH YOU.

SHOULD THE PROGRAM PROVE DEFECTIVE, YOU ASSUME THE COST OF ALL NECESSARY SERVICING, REPAIR OR CORRECTION. IN NO EVENT UNLESS REQUIRED BY APPLICABLE LAW OR AGREED TO IN WRITING WILL ANY COPYRIGHT HOLDER, OR ANY OTHER PARTY WHO MAY MODIFY AND/OR REDISTRIBUTE THE PROGRAM AS PERMITTED ABOVE, BE LIABLE TO YOU FOR DAMAGES, INCLUDING ANY GENERAL, SPECIAL, INCIDENTAL OR CONSEQUENTIAL DAMAGES ARISING OUT OF THE USE OR INABILITY TO USE THE PROGRAM (INCLUDING BUT NOT LIMITED TO LOSS OF DATA OR DATA BEING RENDERED INACCURATE OR LOSSES SUSTAINED BY YOU OR THIRD PARTIES OR A FAILURE OF THE PROGRAM TO OPERATE WITH ANY OTHER PROGRAMS), EVEN IF SUCH HOLDER

OR OTHER PARTY HAS BEEN ADVISED OF THE POSSIBILITY OF SUCH DAMAGES.

## END OF TERMS AND CONDITIONS How to Apply These Terms to Your New Programs

If you develop a new program, and you want it to be of the greatest possible use to the public, the best way to achieve this is to make it free software which everyone can redistribute and change under these terms.

To do so, attach the following notices to the program. It is safest to attach them to the start of each source file to most effectively convey the exclusion of warranty; and each file should have at least the "copyright" line and a pointer to where the full notice is found.

<one line to give the program's name and a brief idea of what it does.> Copyright (C) <year> <name of author>

This program is free software; you can redistribute it and/or modify it under the terms of the GNU General Public License as published by the Free Software Foundation; either version 2 of the License, or (at your option) any later version.

This program is distributed in the hope that it will be useful, but WITHOUT ANY WARRANTY; without even the implied warranty of MERCHANTABILITY or FITNESS FOR A PARTICULAR PURPOSE. See the GNU General Public License for more details.

You should have received a copy of the GNU General Public License along with this program; if not, write to the Free Software Foundation, Inc., 51 Franklin Street, Fifth Floor, Boston, MA 02110-1301, USA.

Also add information on how to contact you by electronic and paper mail.

If the program is interactive, make it output a short notice like this when it starts in an interactive mode: Gnomovision version 69, Copyright (C) year name of author Gnomovision comes with ABSOLUTELY NO WARRANTY; for details type 'show w'.

This is free software, and you are welcome to redistribute it under certain conditions; type 'show c' for details.

The hypothetical commands 'show w' and 'show c' should show the appropriate parts of the General Public License. Of course, the commands you use may be called something other than 'show w' and 'show c'; they could even be mouse-clicks or menu items--whatever suits your program.

You should also get your employer (if you work as a programmer) or your school, if any, to sign a "copyright disclaimer" for the program, if necessary. Here is a sample; alter the names:

Yoyodyne, Inc., hereby disclaims all copyright interest in the program 'Gnomovision' (which makes passes at compilers) written by James Hacker.

<signature of Ty Coon>, 1 April 1989

Ty Coon, President of Vice

This General Public License does not permit incorporating your program into proprietary programs.

If your program is a subroutine library, you may consider it more useful to permit linking proprietary applications with the library. If this is what you want to do, use the GNU Library General Public License instead of this License.

## GNU LESSER GENERAL PUBLIC LICENSE

Version 2.1, February 1999

Copyright (C) 1991, 1999 Free Software Foundation, Inc. 51 Franklin Street, Fifth Floor,

Boston, MA 02110-1301, USA. Everyone is permitted to copy and distribute verbatim copies of this license document, but changing it is not allowed. [This is the first released version of the Lesser GPL. It also counts as the successor of the GNU Library Public License, version 2, hence the version number 2.1.]

## Preamble

The licenses for most software are designed to take away your freedom to share and change it. By contrast, the GNU General Public Licenses are intended to guarantee your freedom to share and change free software—to make sure the software is free for all its users.

This license, the Lesser General Public License, applies to some specially designated software packages—typically libraries—of the Free Software Foundation and other authors who decide to use it. You can use it too, but we suggest you first think carefully about whether this license or the ordinary General Public License is the better strategy to use in any particular case, based on the explanations below. When we speak of free software, we are referring to freedom of use, not price. Our General Public Licenses are designed to make sure that you have the freedom to distribute copies of free software (and charge for this service if you wish); that you receive source code or can get it if you want it; that you can change the software and use pieces of it in new free programs; and that you are informed that you can do these things.

To protect your rights, we need to make restrictions that forbid distributors to deny you these rights or to ask you to surrender these rights. These restrictions translate to certain responsibilities for you if you distribute copies of the library or if you modify it. For example, if you distribute copies of the library, whether gratis or for a fee, you must give the recipients all the rights that we gave you. You must make sure that they, too, receive or can get the source code. If you link other code with the library, you must provide complete object files to the recipients, so that they can relink them with the library after making changes to the library and recompiling it. And you must show them these terms so they know their rights.

We protect your rights with a two-step method: (1) we copyright the library, and (2) we offer you this license, which gives you legal permission to copy, distribute and/or modify the library.

To protect each distributor, we want to make it very clear that there is no warranty for the free library. Also, if the library is modified by someone else and passed on, the recipients should know that what they have is not the original version, so that the original author's reputation will not be affected by problems that might be introduced by others.

Finally, software patents pose a constant threat to the existence of any free program. We wish to make sure that a company cannot effectively restrict the users of a free program by obtaining a restrictive license from a patent holder. Therefore, we insist that any patent license obtained for a version of the library must be consistent with the full freedom of use specified in this license.

Most GNU software, including some libraries, is covered by the ordinary GNU General Public License. This license, the GNU Lesser General Public License, applies to certain designated libraries, and is quite different from the ordinary General Public License. We use this license for certain libraries in order to permit linking those libraries into non-free programs.

When a program is linked with a library, whether statically or using a shared library, the combination of the two is legally speaking a combined work, a

derivative of the original library. The ordinary General Public License therefore permits such linking only if the entire combination fits its criteria of freedom. The Lesser General Public License permits more lax criteria for linking other code with the library.

We call this license the “Lesser” General Public License because it does Less to protect the user's freedom than the ordinary General Public License. It also provides other free software developers Less of an advantage over competing non-free programs. These disadvantages are the reason we use the ordinary General Public License for many libraries. However, the Lesser license provides advantages in certain special circumstances.

For example, on rare occasions, there may be a special need to encourage the widest possible use of a certain library, so that it becomes a de-facto standard. To achieve this, non-free programs must be allowed to use the library. A more frequent case is that a free library does the same job as widely used non-free libraries. In this case, there is little to gain by limiting the free library to free software only, so we use the Lesser General Public License.

In other cases, permission to use a particular library in non-free programs enables a greater number of people to use a large body of free software. For example, permission to use the GNU C Library in non-free programs enables many more people to use the whole GNU operating system, as well as its variant, the GNU/Linux operating system.

Although the Lesser General Public License is Less protective of the users' freedom, it does ensure that the user of a program that is linked with the Library has the freedom and the wherewithal to run that program using a modified version of the Library. The precise terms and conditions for copying, distribution and modification follow. Pay close attention to the difference between a “work based on the library” and a “work that uses the library”. The former contains code derived from the library, whereas the latter must be combined with the library in order to run.

## GNU LESSER GENERAL PUBLIC LICENSE TERMS AND CONDITIONS FOR COPYING, DISTRIBUTION AND MODIFICATION

**0.** This License Agreement applies to any software library or other program which contains a notice placed by the copyright holder or other authorized party saying it may be distributed under the terms of this Lesser General Public License (also called “this License”). Each licensee is addressed as “you”.

A “library” means a collection of software functions and/or data prepared so as to be conveniently linked with application programs (which use some of those functions and data) to form executables.

The “Library”, below, refers to any such software library or work which has been distributed under these terms.

A “work based on the Library” means either the Library or any derivative work under copyright law: that is to say, a work containing the Library or a portion of it, either verbatim or with modifications and/or translated straightforwardly into another language. (Hereinafter, translation is included without limitation in the term “modification”.)

“Source code” for a work means the preferred form of the work for making modifications to it. For a library, complete source code means all the source code for all modules it contains, plus any associated interface definition files, plus the scripts used to control compilation and installation of the library. Activities other than copying, distribution and modification are not covered by this License; they are outside its scope. The act of running a program

using the Library is not restricted, and output from such a program is covered only if its contents constitute a work based on the Library (independent of the use of the Library in a tool for writing it). Whether that is true depends on what the Library does and what the program that uses the Library does.

**1.** You may copy and distribute verbatim copies of the Library's complete source code as you receive it, in any medium, provided that you conspicuously and appropriately publish on each copy an appropriate copyright notice and disclaimer of warranty; keep intact all the notices that refer to this License and to the absence of any warranty; and distribute a copy of this License along with the Library.

You may charge a fee for the physical act of transferring a copy, and you may at your option offer warranty protection in exchange for a fee.

**2.** You may modify your copy or copies of the Library or any portion of it, thus forming a work based on the Library, and copy and distribute such modifications or work under the terms of Section 1 above, provided that you also meet all of these conditions:

**a)** The modified work must itself be a software library.

**b)** You must cause the files modified to carry prominent notices stating that you changed the files and the date of any change.

**c)** You must cause the whole of the work to be licensed at no charge to all third parties under the terms of this License.

**d)** If a facility in the modified Library refers to a function or a table of data to be supplied by an application program that uses the facility, other than as an argument passed when the facility is invoked, then you must make a good faith effort to ensure that, in the event an application does not supply such function or table, the facility still operates, and performs whatever part of its purpose remains meaningful.

(For example, a function in a library to compute square roots has a purpose that is entirely well-defined independent of the application. Therefore, Subsection 2d requires that any application-supplied function or table used by this function must be optional: if the application does not supply it, the square root function must still compute square roots.)

These requirements apply to the modified work as a whole. If identifiable sections of that work are not derived from the Library, and can be reasonably considered independent and separate works in themselves, then this License, and its terms, do not apply to those sections when you distribute them as separate works. But when you distribute the same sections as part of a whole which is a work based on the Library, the distribution of the whole must be on the terms of this License, whose permissions for other licensees extend to the entire whole, and thus to each and every part regardless of who wrote it. Thus, it is not the intent of this section to claim rights or contest your rights to work written entirely by you; rather, the intent is to exercise the right to control the distribution of derivative or collective works based on the Library.

In addition, mere aggregation of another work not based on the Library with the Library (or with a work based on the Library) on a volume of a storage or distribution medium does not bring the other work under the scope of this License.

**3.** You may opt to apply the terms of the ordinary GNU General Public License instead of this License to a given copy of the Library. To do this, you must alter all the notices that refer to this License, so that they refer to the ordinary GNU General Public License, version 2, instead of to this License. (If a

newer version than version 2 of the ordinary GNU General Public License has appeared, then you can specify that version instead if you wish.) Do not make any other change in these notices. Once this change is made in a given copy, it is irreversible for that copy, so the ordinary GNU General Public License applies to all subsequent copies and derivative works made from that copy. This option is useful when you wish to copy part of the code of the Library into a program that is not a library.

**4.** You may copy and distribute the Library (or a portion or derivative of it, under Section 2) in object code or executable form under the terms of Sections 1 and 2 above provided that you accompany it with the complete corresponding machine-readable source code, which must be distributed under the terms of Sections 1 and 2 above on a medium customarily used for software interchange. If distribution of object code is made by offering access to copy from a designated place, then offering equivalent access to copy the source code from the same place satisfies the requirement to distribute the source code, even though third parties are not compelled to copy the source along with the object code.

**5.** A program that contains no derivative of any portion of the Library, but is designed to work with the Library by being compiled or linked with it, is called a “work that uses the Library”. Such a work, in isolation, is not a derivative work of the Library, and therefore falls outside the scope of this License. However, linking a “work that uses the Library” with the Library creates an executable that is a derivative of the Library (because it contains portions of the Library), rather than a “work that uses the library”. The executable is therefore covered by this License. Section 6 states terms for distribution of such executables.

When a “work that uses the Library” uses material from a header file that is part of the Library, the object code for the work may be a derivative work of the Library even though the source code is not. Whether this is true is especially significant if the work can be linked without the Library, or if the work is itself a library. The threshold for this to be true is not precisely defined by law.

If such an object file uses only numerical parameters, data structure layouts and accessors, and small macros and small inline functions (ten lines or less in length), then the use of the object file is unrestricted, regardless of whether it is legally a derivative work. (Executables containing this object code plus portions of the Library will still fall under Section 6.)

Otherwise, if the work is a derivative of the Library, you may distribute the object code for the work under the terms of Section 6. Any executables containing that work also fall under Section 6, whether or not they are linked directly with the Library itself.

**6.** As an exception to the Sections above, you may also combine or link a “work that uses the Library” with the Library to produce a work containing portions of the Library, and distribute that work under terms of your choice, provided that the terms permit modification of the work for the customer’s own use and reverse engineering for debugging such modifications.

You must give prominent notice with each copy of the work that the Library is used in it and that the Library and its use are covered by this License. You must supply a copy of this License. If the work during execution displays copyright notices, you must include the copyright notice for the Library among them, as well as a reference directing the user

to the copy of this License. Also, you must do one of these things:

**a)** Accompany the work with the complete corresponding machine-readable source code for the Library including whatever changes were used in the work (which must be distributed under Sections 1 and 2 above); and, if the work is an executable linked with the Library, with the complete machine-readable “work that uses the Library”, as object code and/or source code, so that the user can modify the Library and then relink to produce a modified executable containing the modified Library. (It is understood that the user who changes the contents of definitions files in the Library will not necessarily be able to recompile the application to use the modified definitions.)

**b)** Use a suitable shared library mechanism for linking with the Library. A suitable mechanism is one that (1) uses at run time a copy of the library already present on the user’s computer system, rather than copying library functions into the executable, and (2) will operate properly with a modified version of the library, if the user installs one, as long as the modified version is interface-compatible with the version that the work was made with.

**c)** Accompany the work with a written offer, valid for at least three years, to give the same user the materials specified in Subsection 6a, above, for a charge no more than the cost of performing this distribution.

**d)** If distribution of the work is made by offering access to copy from a designated place, offer equivalent access to copy the above specified materials from the same place.

**e)** Verify that the user has already received a copy of these materials or that you have already sent this user a copy.

For an executable, the required form of the “work that uses the Library” must include any data and utility programs needed for reproducing the executable from it. However, as a special exception, the materials to be distributed need not include anything that is normally distributed (in either source or binary form) with the major components (compiler, kernel, and so on) of the operating system on which the executable runs, unless that component itself accompanies the executable.

It may happen that this requirement contradicts the license restrictions of other proprietary libraries that do not normally accompany the operating system. Such a contradiction means you cannot use both them and the Library together in an executable that you distribute.

**7.** You may place library facilities that are a work based on the Library side-by-side in a single library together with other library facilities not covered by this License, and distribute such a combined library, provided that the separate distribution of the work based on the Library and of the other library facilities is otherwise permitted, and provided that you do these two things:

**a)** Accompany the combined library with a copy of the same work based on the Library, uncombined with any other library facilities. This must be distributed under the terms of the Sections above.

**b)** Give prominent notice with the combined library of the fact that part of it is a work based on the Library, and explaining where to find the accompanying uncombined form of the same work.

**8.** You may not copy, modify, sublicense, link with, or distribute the Library except as expressly provided under this License. Any attempt otherwise to copy, modify, sublicense, link with, or distribute the Library is void, and will automatically terminate your rights under this License. However, parties who have received copies, or rights, from you under this

License will not have their licenses terminated so long as such parties remain in full compliance.

**9.** You are not required to accept this License, since you have not signed it. However, nothing else grants you permission to modify or distribute the Library or its derivative works. These actions are prohibited by law if you do not accept this License. Therefore, by modifying or distributing the Library (or any work based on the Library), you indicate your acceptance of this License to do so, and all its terms and conditions for copying, distributing or modifying the Library or works based on it.

**10.** Each time you redistribute the Library (or any work based on the Library), the recipient automatically receives a license from the original licensor to copy, distribute, link with or modify the Library subject to these terms and conditions. You may not impose any further restrictions on the recipients’ exercise of the rights granted herein. You are not responsible for enforcing compliance by third parties with this License.

**11.** If, as a consequence of a court judgment or allegation of patent infringement or for any other reason (not limited to patent issues), conditions are imposed on you (whether by court order, agreement or otherwise) that contradict the conditions of this License, they do not excuse you from the conditions of this License. If you cannot distribute so as to satisfy simultaneously your obligations under this License and any other pertinent obligations, then as a consequence you may not distribute the Library at all. For example, if a patent license would not permit royalty-free redistribution of the Library by all those who receive copies directly or indirectly through you, then the only way you could satisfy both it and this License would be to refrain entirely from distribution of the Library.

If any portion of this section is held invalid or unenforceable under any particular circumstance, the balance of the section is intended to apply, and the section as a whole is intended to apply in other circumstances.

It is not the purpose of this section to induce you to infringe any patents or other property right claims or to contest validity of any such claims; this section has the sole purpose of protecting the integrity of the free software distribution system which is implemented by public license practices. Many people have made generous contributions to the wide range of software distributed through that system in reliance on consistent application of that system; it is up to the author/donor to decide if he or she is willing to distribute software through any other system and a licensee cannot impose that choice.

This section is intended to make thoroughly clear what is believed to be a consequence of the rest of this License.

**12.** If the distribution and/or use of the Library is restricted in certain countries either by patents or by copyrighted interfaces, the original copyright holder who places the Library under this License may add an explicit geographical distribution limitation excluding those countries, so that distribution is permitted only in or among countries not thus excluded. In such case, this License incorporates the limitation as if written in the body of this License.

**13.** The Free Software Foundation may publish revised and/or new versions of the Lesser General Public License from time to time. Such new versions will be similar in spirit to the present version, but may differ in detail to address new problems or concerns.

Each version is given a distinguishing version number.

If the Library specifies a version number of this License which applies to it and “any later version”,

you have the option of following the terms and conditions either of that version or of any later version published by the Free Software Foundation. If the Library does not specify a license version number, you may choose any version ever published by the Free Software Foundation.

**14.** If you wish to incorporate parts of the Library into other free programs whose distribution conditions are incompatible with these, write to the author to ask for permission. For software which is copyrighted by the Free Software Foundation, write to the Free Software Foundation; we sometimes make exceptions for this. Our decision will be guided by the two goals of preserving the free status of all derivatives of our free software and of promoting the sharing and reuse of software generally.

## NO WARRANTY

**15.** BECAUSE THE LIBRARY IS LICENSED FREE OF CHARGE, THERE IS NO WARRANTY FOR THE LIBRARY, TO THE EXTENT PERMITTED BY APPLICABLE LAW. EXCEPT WHEN OTHERWISE STATED IN WRITING THE COPYRIGHT HOLDERS AND/OR OTHER PARTIES PROVIDE THE LIBRARY "AS IS" WITHOUT WARRANTY OF ANY KIND, EITHER EXPRESSED OR IMPLIED, INCLUDING, BUT NOT LIMITED TO, THE IMPLIED WARRANTIES OF MERCHANTABILITY AND FITNESS FOR A PARTICULAR PURPOSE. THE ENTIRE RISK AS TO THE QUALITY AND PERFORMANCE OF THE LIBRARY IS WITH YOU. SHOULD THE LIBRARY PROVE DEFECTIVE, YOU ASSUME THE COST OF ALL NECESSARY SERVICING, REPAIR OR CORRECTION.

**16.** IN NO EVENT UNLESS REQUIRED BY APPLICABLE LAW OR AGREED TO IN WRITING WILL ANY COPYRIGHT HOLDER, OR ANY OTHER PARTY WHO MAY MODIFY AND/OR REDISTRIBUTE THE LIBRARY AS PERMITTED ABOVE, BE LIABLE TO YOU FOR DAMAGES, INCLUDING ANY GENERAL, SPECIAL, INCIDENTAL OR CONSEQUENTIAL DAMAGES ARISING OUT OF THE USE OR INABILITY TO USE THE LIBRARY (INCLUDING BUT NOT LIMITED TO LOSS OF DATA OR DATA BEING RENDERED INACCURATE OR LOSSES SUSTAINED BY YOU OR THIRD PARTIES OR A FAILURE OF THE LIBRARY TO OPERATE WITH ANY OTHER SOFTWARE), EVEN IF SUCH HOLDER OR OTHER PARTY HAS BEEN ADVISED OF THE POSSIBILITY OF SUCH DAMAGES.

## END OF TERMS AND CONDITIONS

### How to Apply These Terms to Your New Libraries

If you develop a new library, and you want it to be of the greatest possible use to the public, we recommend making it free software that everyone can redistribute and change. You can do so by permitting redistribution under these terms (or, alternatively, under the terms of the ordinary General Public License).

To apply these terms, attach the following notices to the library. It is safest to attach them to the start of each source file to most effectively convey the exclusion of warranty; and each file should have at least the "copyright" line and a pointer to where the full notice is found.

<one line to give the library's name and a brief idea of what it does.>

Copyright (C) <year> <name of author>

This library is free software; you can redistribute it and/or modify it under the terms of the GNU Lesser General Public license as published by the Free Software Foundation; either version 2.1 of the License, or (at your option) any later version. This library is distributed in the hope that it will be useful, but WITHOUT ANY WARRANTY; without even the implied warranty of MERCHANTABILITY or FITNESS FOR A PARTICULAR PURPOSE. See the GNU Lesser General Public License for more details. You should have received a copy of the GNU Lesser General Public License along with this library; if not, write to the Free Software Foundation, Inc., 51 Franklin Street, Fifth Floor, Boston, MA 02110-1301, USA.

Also add information on how to contact you by electronic and paper mail.

You should also get your employer (if you work as a programmer) or your school, if any, to sign a "copyright disclaimer" for the library, if necessary.

Here is a sample; alter the names:

Yoyodyne, Inc., hereby disclaims all copyright interest in the library 'Frob' (a library for tweaking knobs) written by James Random Hacker.

<signature of Ty Coon>, 1 April 1990

Ty Coon, President of Vice

## Notification of BSD

Redistribution and use in source and binary forms, with or without modification, are permitted provided that the following conditions are met:

**1.** Redistributions of source code must retain the above copyright notice, this list of conditions and the following disclaimer.

**2.** Redistributions in binary form must reproduce the above copyright notice, this list of conditions and the following disclaimer in the documentation and/or other materials provided with the distribution.

**3.** All advertising materials mentioning features or use of this software must display the following acknowledgment:

**4.** Neither the name of the following developers nor the names of its contributors may be used to endorse or promote products derived from this software without specific prior written permission.

THIS SOFTWARE IS PROVIDED BY THE REGENTS AND CONTRIBUTORS "AS IS" AND ANY EXPRESS OR IMPLIED WARRANTIES, INCLUDING, BUT NOT LIMITED TO, THE IMPLIED WARRANTIES OF MERCHANTABILITY AND FITNESS FOR A PARTICULAR PURPOSE ARE DISCLAIMED. IN NO EVENT SHALL THE REGENTS OR CONTRIBUTORS BE LIABLE FOR ANY DIRECT, INDIRECT, INCIDENTAL, SPECIAL, EXEMPLARY, OR CONSEQUENTIAL DAMAGES (INCLUDING, BUT NOT LIMITED TO, PROCUREMENT OF SUBSTITUTE GOODS OR SERVICES; LOSS OF USE, DATA, OR PROFITS; OR BUSINESS INTERRUPTION) HOWEVER CAUSED AND ON ANY THEORY OF LIABILITY, WHETHER IN CONTRACT, STRICT LIABILITY, OR TORT (INCLUDING NEGLIGENCE OR OTHERWISE) ARISING IN ANY WAY OUT OF THE USE OF THIS SOFTWARE, EVEN IF ADVISED OF THE POSSIBILITY OF SUCH DAMAGE.

The following notices are required to satisfy the license terms of the software that we have mentioned in this document:

This product includes software developed by the NetBSD Foundation, Inc. and its contributors.

This product includes software developed by the University of California, Berkeley and its contributors.

This product includes software developed for the NetBSD Project. See <http://www.NetBSD.org/> for information about NetBSD.

This product includes software developed by Christos Zoulas.

This product includes software developed by Niels Provos.

This product includes software developed by the University of California, Lawrence Berkeley Laboratory.

This product includes software developed by WIDE Project and its contributors.

This product includes software developed by Brian Aker.

This product includes software developed by Danga Interactive, Inc.

## INDEPENDENT JPEG GROUP SOFTWARE

This software is based in part on the work of the Independent JPEG Group.

## SOFTWARE DEVELOPED BY THE OPENSLL PROJECT FOR USE IN THE SSL TOOLKIT

Copyright (c) 1998-2008 The OpenSSL Project. All rights reserved.

Redistribution and use in source and binary forms, with or without modification, are permitted provided that the following conditions are met:

**1.** Redistributions of source code must retain the above copyright notice, this list of conditions and the following disclaimer.

**2.** Redistributions in binary form must reproduce the above copyright notice, this list of conditions and the following disclaimer in the documentation and/or other materials provided with the distribution.

**3.** All advertising materials mentioning features or use of this software must display the following acknowledgment: "This product includes software developed by the OpenSSL Project for use in the OpenSSL Toolkit. (<<http://www.openssl.org/>>)"

**4.** The names "OpenSSL Toolkit" and "OpenSSL Project" must not be used to endorse or promote products derived from this software without prior written permission. For written permission, please contact [openssl-core@openssl.org](mailto:openssl-core@openssl.org).

**5.** Products derived from this software may not be called "OpenSSL" nor may "OpenSSL" appear in their names without prior written permission of the OpenSSL Project.

**6.** Redistributions of any form whatsoever must retain the following acknowledgment: "This product includes software developed by the OpenSSL Project for use in the OpenSSL Toolkit (<<http://www.openssl.org/>>)"

THIS SOFTWARE IS PROVIDED BY THE OPENSLL PROJECT "AS IS" AND ANY EXPRESS OR IMPLIED WARRANTIES, INCLUDING, BUT NOT LIMITED TO, THE IMPLIED WARRANTIES OF MERCHANTABILITY AND FITNESS FOR A PARTICULAR PURPOSE ARE DISCLAIMED. IN NO EVENT SHALL THE OPENSLL PROJECT OR ITS CONTRIBUTORS BE LIABLE FOR ANY DIRECT, INDIRECT, INCIDENTAL, SPECIAL, EXEMPLARY, OR CONSEQUENTIAL DAMAGES (INCLUDING, BUT NOT LIMITED TO, PROCUREMENT OF SUBSTITUTE GOODS OR SERVICES; LOSS OF USE, DATA, OR PROFITS; OR BUSINESS INTERRUPTION)

HOWEVER CAUSED AND ON ANY THEORY OF LIABILITY, WHETHER IN CONTRACT, STRICT LIABILITY, OR TORT (INCLUDING NEGLIGENCE OR OTHERWISE) ARISING IN ANY WAY OUT OF THE USE OF THIS SOFTWARE, EVEN IF ADVISED OF THE POSSIBILITY OF SUCH DAMAGE.

This product includes cryptographic software written by Eric Young (eay@cryptsoft.com). This product includes software written by Tim Hudson (tjh@cryptsoft.com). Original SSLeay License

-----  
Copyright (C) 1995-1998 Eric Young  
(eay@cryptsoft.com)

All rights reserved.

This package is an SSL implementation written by Eric Young (eay@cryptsoft.com).

The implementation was written so as to conform with Netscapes SSL.

This library is free for commercial and non-commercial use as long as the following conditions are adhered to.

The following conditions apply to all code found in this distribution, be it the RC4, RSA, lhash, DES, etc., code; not just the SSL code. The SSL documentation included with this distribution is covered by the same copyright terms except that the holder is Tim Hudson (tjh@cryptsoft.com).

Copyright remains Eric Young's, and as such any Copyright notices in the code are not to be removed. If this package is used in a product, Eric Young should be given attribution as the author of the parts of the library used. This can be in the form of a textual message at program startup or in documentation (online or textual) provided with the package.

Redistribution and use in source and binary forms, with or without modification, are permitted provided that the following conditions are met:

1. Redistributions of source code must retain the copyright notice, this list of conditions and the following disclaimer.
2. Redistributions in binary form must reproduce the above copyright notice, this list of conditions and the following disclaimer in the documentation and/or other materials provided with the distribution.
3. All advertising materials mentioning features or use of this software must display the following acknowledgement: "This product includes cryptographic software written by Eric Young (eay@cryptsoft.com)".

The word 'cryptographic' can be left out if the routines from the library being used are not cryptographic related:-).

4. If you include any Windows specific code (or a derivative thereof) from the apps directory (application code) you must include an acknowledgement: "This product includes software written by Tim Hudson (tjh@cryptsoft.com)". THIS SOFTWARE IS PROVIDED BY ERIC YOUNG "AS IS" AND ANY EXPRESS OR IMPLIED WARRANTIES, INCLUDING, BUT NOT LIMITED TO, THE IMPLIED WARRANTIES OF MERCHANTABILITY AND FITNESS FOR A PARTICULAR PURPOSE ARE DISCLAIMED. IN NO EVENT SHALL THE AUTHOR OR CONTRIBUTORS BE LIABLE FOR ANY DIRECT, INDIRECT, INCIDENTAL, SPECIAL, EXEMPLARY, OR CONSEQUENTIAL DAMAGES (INCLUDING, BUT NOT LIMITED TO, PROCUREMENT OF SUBSTITUTE GOODS OR SERVICES; LOSS OF USE, DATA, OR PROFITS; OR BUSINESS INTERRUPTION) HOWEVER CAUSED AND ON ANY THEORY OF LIABILITY, WHETHER IN CONTRACT, STRICT LIABILITY, OR TORT (INCLUDING NEGLIGENCE OR OTHERWISE) ARISING IN

ANY WAY OUT OF THE USE OF THIS SOFTWARE, EVEN IF ADVISED OF THE POSSIBILITY OF SUCH DAMAGE.

The license and distribution terms for any publically available version or derivative of this code cannot be changed. i.e. this code cannot simply be copied and put under another distribution license [including the GNU Public License.]

## =====

### FREETYPE/FREETYPE2 SOFTWARE

The software is based in part of the work of the FreeType Team.

### Notification of MIT

EXPAT

Copyright (c) 1998, 1999, 2000 Thai Open Source Software Center Ltd and Clark Cooper  
Copyright (c) 2001, 2002, 2003, 2004, 2005, 2006 Expat maintainers.

JSONcpp Copyright (c) 2007-2010 Baptiste Lepilleur

yaml-cpp Copyright (c) 2008 Jesse Beder.

cJSON Copyright (c) 2009 Dave Gamble

GIFLIB Copyright (c) 1997 Eric S. Raymond

PyYAML Copyright (c) 2006 Kirill Simonov

Parson Copyright (c) 2012 - 2014 Krzysztof Gabis

Permission is hereby granted, free of charge, to any person obtaining a copy of this software and associated documentation files (the "Software"), to deal in the Software without restriction, including without limitation the rights to use, copy, modify, merge, publish, distribute, sublicense, and/or sell copies of the Software, and to permit persons to whom the Software is furnished to do so, subject to the following conditions:

The above copyright notice and this permission notice shall be included in all copies or substantial portions of the Software.

THE SOFTWARE IS PROVIDED "AS IS", WITHOUT WARRANTY OF ANY KIND, EXPRESS OR IMPLIED, INCLUDING BUT NOT LIMITED TO THE WARRANTIES OF MERCHANTABILITY, FITNESS FOR A PARTICULAR PURPOSE AND NONINFRINGEMENT. IN NO EVENT SHALL THE AUTHORS OR COPYRIGHT HOLDERS BE LIABLE FOR ANY CLAIM, DAMAGES OR OTHER LIABILITY, WHETHER IN AN ACTION OF CONTRACT, TORT OR OTHERWISE, ARISING FROM, OUT OF OR IN CONNECTION WITH THE SOFTWARE OR THE USE OR OTHER DEALINGS IN THE SOFTWARE.

### =====

### CURL SOFTWARE

COPYRIGHT AND PERMISSION NOTICE.

Copyright (c)

1996 - 2012, Daniel Stenberg, <daniel@haxx.se>. All rights reserved.

Permission to use, copy, modify, and distribute this software for any purpose with or without fee is hereby granted, provided that the above copyright notice and this permission notice appear in all copies.

THE SOFTWARE IS PROVIDED "AS IS", WITHOUT WARRANTY OF ANY KIND, EXPRESS OR IMPLIED, INCLUDING BUT NOT LIMITED TO THE WARRANTIES OF MERCHANTABILITY, FITNESS FOR A PARTICULAR PURPOSE AND NONINFRINGEMENT OF THIRD PARTY RIGHTS. IN NO EVENT SHALL THE AUTHORS OR COPYRIGHT HOLDERS BE LIABLE FOR ANY CLAIM, DAMAGES OR OTHER

LIABILITY, WHETHER IN AN ACTION OF CONTRACT, TORT OR OTHERWISE, ARISING FROM, OUT OF OR IN CONNECTION WITH THE SOFTWARE OR THE USE OR OTHER DEALINGS IN THE SOFTWARE. Except as contained in this notice, the name of a copyright holder shall not be used in advertising or otherwise to promote the sale, use or other dealings in this Software without prior written authorization of the copyright holder.

### =====

### klibc and jemalloc

All of the documentation and software included in the 4.4BSD and 4.4BSD-Lite Releases is copyrighted by The Regents of the University of California.

Copyright 1979, 1980, 1983, 1986, 1988, 1989, 1991, 1992, 1993, 1994 The Regents of the University of California.

All rights reserved.

Redistribution and use in source and binary forms, with or without modification, are permitted provided that the following conditions are met:

Redistributions of source code must retain the above copyright notice, this list of conditions and the following disclaimer.

Redistributions in binary form must reproduce the above copyright notice, this list of conditions and the following disclaimer in the documentation and/or other materials provided with the distribution.

All advertising materials mentioning features or use of this software must display the following acknowledgement:

This product includes software developed by the University of California, Berkeley and its contributors.

Neither the name of the University nor the names of its contributors may be used to endorse or promote products derived from this software without specific prior written permission.

THIS SOFTWARE IS PROVIDED BY THE REGENTS AND CONTRIBUTORS "AS IS" AND ANY EXPRESS OR IMPLIED WARRANTIES, INCLUDING, BUT NOT LIMITED TO, THE IMPLIED WARRANTIES OF MERCHANTABILITY AND FITNESS FOR A PARTICULAR PURPOSE ARE DISCLAIMED. IN NO EVENT SHALL THE REGENTS OR CONTRIBUTORS BE LIABLE FOR ANY DIRECT, INDIRECT, INCIDENTAL, SPECIAL, EXEMPLARY, OR CONSEQUENTIAL DAMAGES (INCLUDING, BUT NOT LIMITED TO, PROCUREMENT OF SUBSTITUTE GOODS OR SERVICES; LOSS OF USE, DATA, OR PROFITS; OR BUSINESS INTERRUPTION) HOWEVER CAUSED AND ON ANY THEORY OF LIABILITY, WHETHER IN CONTRACT, STRICT LIABILITY, OR TORT (INCLUDING NEGLIGENCE OR OTHERWISE) ARISING IN ANY WAY OUT OF THE USE OF THIS SOFTWARE, EVEN IF ADVISED OF THE POSSIBILITY OF SUCH DAMAGE.

The Institute of Electrical and Electronics Engineers and the American National Standards Committee X3, on Information Processing Systems have given us permission to reprint portions of their documentation.

In the following statement, the phrase "this text" refers

to portions of the system documentation.

Portions of this text are reprinted and reproduced in electronic form in the second BSD Networking Software Release, from IEEE Std 1003.1-1988,

IEEE Standard Portable Operating System Interface for Computer Environments (POSIX), copyright C 1988 by the Institute of Electrical and Electronics Engineers, Inc. In the event of any discrepancy between these versions and the original IEEE Standard, the original IEEE Standard is the referee document.

In the following statement, the phrase "This material" refers to portions of the system documentation.

This material is reproduced with permission from American National Standards Committee X3, on Information Processing Systems. Computer and Business Equipment Manufacturers Association (CBEMA), 311 First St., NW, Suite 500, Washington, DC 20001-2178. The developmental work of Programming Language C was completed by the X3J11 Technical Committee.

The views and conclusions contained in the software and documentation are those of the authors and should not be interpreted as representing official policies, either expressed or implied, of the Regents of the University of California.

### Big5 Font(DynaComware)

The DynaFont used on the screen display are solely develop by DynaComware.

### icu(libic)

ICU License - ICU 1.8.1 and later  
COPYRIGHT AND PERMISSION NOTICE  
Copyright (c) 1995-2012 International Business Machines Corporation and others  
All rights reserved.

Permission is hereby granted, free of charge, to any person obtaining a copy of this software and associated documentation files (the "Software"), to deal in the Software without restriction, including without limitation the rights to use, copy, modify, merge, publish, distribute, and/or sell copies of the Software, and to permit persons to whom the Software is furnished to do so, provided that the above copyright notice(s) and this permission notice appear in all copies of the Software and that both the above copyright notice(s) and this permission notice appear in supporting documentation.

THE SOFTWARE IS PROVIDED "AS IS", WITHOUT WARRANTY OF ANY KIND, EXPRESS OR IMPLIED, INCLUDING BUT NOT LIMITED TO THE WARRANTIES OF MERCHANTABILITY, FITNESS FOR A PARTICULAR PURPOSE AND NONINFRINGEMENT OF THIRD PARTY RIGHTS. IN NO EVENT SHALL THE COPYRIGHT HOLDER OR HOLDERS INCLUDED IN THIS NOTICE BE LIABLE FOR ANY CLAIM, OR ANY SPECIAL INDIRECT OR CONSEQUENTIAL DAMAGES, OR ANY DAMAGES WHATSOEVER RESULTING FROM LOSS OF USE, DATA OR PROFITS, WHETHER IN AN ACTION OF CONTRACT, NEGLIGENCE OR OTHER TORTIOUS ACTION, ARISING OUT OF OR IN CONNECTION WITH THE USE OR PERFORMANCE OF THIS SOFTWARE.

Except as contained in this notice, the name of a copyright holder shall not be used in advertising or otherwise to promote the sale, use or other dealings in this Software without prior written authorization of the copyright holder.

All trademarks and registered trademarks mentioned herein are the property of their respective owners.

### dhcpd

Copyright (c) 2004-2011 by Internet Systems Consortium, Inc. ("ISC")

Copyright (c) 1995-2003 by Internet Software Consortium

Permission to use, copy, modify, and distribute this software for any purpose with or without fee is hereby granted, provided that the above copyright notice and this permission notice appear in all copies.

THE SOFTWARE IS PROVIDED "AS IS" AND ISC DISCLAIMS ALL WARRANTIES WITH REGARD TO THIS SOFTWARE INCLUDING ALL IMPLIED WARRANTIES OF MERCHANTABILITY AND FITNESS. IN NO EVENT SHALL ISC BE LIABLE FOR ANY SPECIAL, DIRECT, INDIRECT, OR CONSEQUENTIAL DAMAGES OR ANY DAMAGES WHATSOEVER RESULTING FROM LOSS OF USE, DATA OR PROFITS, WHETHER IN AN ACTION OF CONTRACT, NEGLIGENCE OR OTHER TORTIOUS ACTION, ARISING OUT OF OR IN CONNECTION WITH THE USE OR PERFORMANCE OF THIS SOFTWARE.

Internet Systems Consortium, Inc.

950 Charter Street  
Redwood City, CA 94063  
info@isc.org  
<https://www.isc.org/>

### libevent

Libevent is available for use under the following license, commonly known as the 3-clause (or "modified") BSD license:

Copyright (c) 2000-2007 Niels Provos

<provos@citi.umich.edu>

Copyright (c) 2007-2010 Niels Provos and Nick Mathewson

Redistribution and use in source and binary forms, with or without modification, are permitted provided that the following conditions are met:

1. Redistributions of source code must retain the above copyright notice, this list of conditions and the following disclaimer.
2. Redistributions in binary form must reproduce the above copyright notice, this list of conditions and the following disclaimer in the documentation and/or other materials provided with the distribution.
3. The name of the author may not be used to endorse or promote products derived from this software without specific prior written permission.

THIS SOFTWARE IS PROVIDED BY THE AUTHOR "AS IS" AND ANY EXPRESS OR IMPLIED WARRANTIES, INCLUDING, BUT NOT LIMITED TO, THE IMPLIED WARRANTIES OF MERCHANTABILITY AND FITNESS FOR A PARTICULAR PURPOSE ARE DISCLAIMED.

IN NO EVENT SHALL THE AUTHOR BE LIABLE FOR ANY DIRECT, INDIRECT, INCIDENTAL, SPECIAL, EXEMPLARY, OR CONSEQUENTIAL DAMAGES (INCLUDING, BUT NOT LIMITED TO, PROCUREMENT OF SUBSTITUTE GOODS OR SERVICES; LOSS OF USE, DATA, OR PROFITS; OR BUSINESS INTERRUPTION) HOWEVER CAUSED AND ON ANY THEORY OF LIABILITY, WHETHER IN CONTRACT, STRICT LIABILITY, OR TORT (INCLUDING NEGLIGENCE OR OTHERWISE) ARISING IN ANY WAY OUT OF THE USE OF THIS SOFTWARE, EVEN IF ADVISED OF THE POSSIBILITY OF SUCH DAMAGE.

Portions of Libevent are based on works by others, also made available by them under the three-clause BSD license above. The copyright notices are available in the corresponding source files; the license is as above.

Here's a list:

log.c:

Copyright (c) 2000 Dug Song  
<dugsong@monkey.org>

Copyright (c) 1993 The Regents of the University of California.

strlcpy.c:

Copyright (c) 1998 Todd C. Miller  
<Todd.Miller@courtesan.com>

win32select.c:

Copyright (c) 2003 Michael A. Davis  
<mike@datanerds.net>

evport.c:

Copyright (c) 2007 Sun Microsystems  
ht-internal.h:

Copyright (c) 2002 Christopher Clark  
minheap-internal.h:

Copyright (c) 2006 Maxim Yegorushkin  
<maxim.yegorushkin@gmail.com>

The arc4module is available under the following, sometimes called the "OpenBSD" license:

Copyright (c) 1996, David Mazieres  
<dm@uun.org>

Copyright (c) 2008, Damien Miller  
<djm@openbsd.org>

Permission to use, copy, modify, and distribute this software for any purpose with or without fee is hereby granted, provided that the above copyright notice and this permission notice appear in all copies.

THE SOFTWARE IS PROVIDED "AS IS" AND THE AUTHOR DISCLAIMS ALL WARRANTIES WITH REGARD TO THIS SOFTWARE INCLUDING ALL IMPLIED WARRANTIES OF MERCHANTABILITY AND FITNESS. IN NO EVENT SHALL THE AUTHOR BE LIABLE FOR ANY SPECIAL, DIRECT, INDIRECT, OR CONSEQUENTIAL DAMAGES OR ANY DAMAGES WHATSOEVER RESULTING FROM LOSS OF USE, DATA OR PROFITS, WHETHER IN AN ACTION OF CONTRACT, NEGLIGENCE OR OTHER TORTIOUS ACTION, ARISING OUT OF OR IN CONNECTION WITH THE USE OR PERFORMANCE OF THIS SOFTWARE.

### boost

Boost Software License - Version 1.0 - August 17th, 2003

Permission is hereby granted, free of charge, to any person or organization obtaining a copy of the software and accompanying documentation covered by this license (the "Software") to use, reproduce, display, distribute, execute, and transmit the Software, and to prepare derivative works of the Software, and to permit third-parties to whom the Software is furnished to do so, all subject to the following:

The copyright notices in the Software and this entire statement, including the above license grant, this restriction and the following disclaimer, must be included in all copies of the Software, in whole or in part, and all derivative works of the Software, unless such copies or derivative works are solely in the form of machine-executable object code generated by a source language processor.

THE SOFTWARE IS PROVIDED "AS IS", WITHOUT WARRANTY OF ANY KIND, EXPRESS OR IMPLIED, INCLUDING BUT NOT LIMITED TO THE WARRANTIES OF

MERCHANTABILITY, FITNESS FOR A PARTICULAR PURPOSE, TITLE AND NON-INFRINGEMENT. IN NO EVENT SHALL THE COPYRIGHT HOLDERS OR ANYONE DISTRIBUTING THE SOFTWARE BE LIABLE FOR ANY DAMAGES OR OTHER LIABILITY, WHETHER IN CONTRACT, TORT OR OTHERWISE, ARISING FROM, OUT OF OR IN CONNECTION WITH THE SOFTWARE OR THE USE OR OTHER DEALINGS IN THE SOFTWARE.

## ppp

Copyrights:

\*\*\*\*\*

All of the code can be freely used and redistributed. The individual source files each have their own copyright and permission notice.

Pppd, pppstats and pppdump are under BSD-style notices. Some of the pppd plugins are GPL'd. Chat is public domain.

## ntp

Copyright (c) University of Delaware 1992-2012. Permission to use, copy, modify, and distribute this software and its documentation for any purpose with or without fee is hereby granted, provided that the above copyright notice appears in all copies and that both the copyright notice and this permission notice appear in supporting documentation, and that the name University of Delaware not be used in advertising or publicity pertaining to distribution of the software without specific, written prior permission. The University of Delaware makes no representations about the suitability this software for any purpose. It is provided "as is" without express or implied warranty.

## libcap

Unless otherwise \*explicitly\* stated, the following text describes the licensed conditions under which the contents of this libcap release may be used and distributed:

Redistribution and use in source and binary forms of libcap, with or without modification, are permitted provided that the following conditions are met:

1. Redistributions of source code must retain any existing copyright notice, and this entire permission notice in its entirety, including the disclaimer of warranties.
2. Redistributions in binary form must reproduce all prior and current copyright notices, this list of conditions, and the following disclaimer in the documentation and/or other materials provided with the distribution.
3. The name of any author may not be used to endorse or promote products derived from this software without their specific prior written permission.

ALTERNATIVELY, this product may be distributed under the terms of the GNU General Public License, in which case the provisions of the GNU GPL are required INSTEAD OF the above restrictions. (This clause is necessary due to a potential conflict between the GNU GPL and the restrictions contained in a BSD-style copyright.)

THIS SOFTWARE IS PROVIDED "AS IS" AND ANY EXPRESS OR IMPLIED WARRANTIES, INCLUDING, BUT NOT LIMITED TO, THE IMPLIED WARRANTIES OF MERCHANTABILITY AND FITNESS FOR A PARTICULAR PURPOSE ARE DISCLAIMED. IN NO EVENT SHALL THE AUTHOR(S) BE

LIABLE FOR ANY DIRECT, INDIRECT, INCIDENTAL, SPECIAL, EXEMPLARY, OR CONSEQUENTIAL DAMAGES (INCLUDING, BUT NOT LIMITED TO, PROCUREMENT OF SUBSTITUTE GOODS OR SERVICES; LOSS OF USE, DATA, OR PROFITS; OR BUSINESS INTERRUPTION) HOWEVER CAUSED AND ON ANY THEORY OF LIABILITY, WHETHER IN CONTRACT, STRICT LIABILITY, OR TORT (INCLUDING NEGLIGENCE OR OTHERWISE) ARISING IN ANY WAY OUT OF THE USE OF THIS SOFTWARE, EVEN IF ADVISED OF THE POSSIBILITY OF SUCH DAMAGE.

## Python®

Python® is a registered trademark of the Python Software Foundation.

## lighttpd

Copyright (c) 2004, Jan Kneschke, incremental All rights reserved.

Redistribution and use in source and binary forms, with or without modification, are permitted provided that the following conditions are met:

- Redistributions of source code must retain the above copyright notice, this list of conditions and the following disclaimer.
- Redistributions in binary form must reproduce the above copyright notice, this list of conditions and the following disclaimer in the documentation and/or other materials provided with the distribution.
- Neither the name of the 'incremental' nor the names of its contributors may be used to endorse or promote products derived from this software without specific prior written permission.

THIS SOFTWARE IS PROVIDED BY THE COPYRIGHT HOLDERS AND CONTRIBUTORS "AS IS" AND ANY EXPRESS OR IMPLIED WARRANTIES, INCLUDING, BUT NOT LIMITED TO, THE IMPLIED WARRANTIES OF MERCHANTABILITY AND FITNESS FOR A PARTICULAR PURPOSE ARE DISCLAIMED. IN NO EVENT SHALL THE COPYRIGHT OWNER OR CONTRIBUTORS BE LIABLE FOR ANY DIRECT, INDIRECT, INCIDENTAL, SPECIAL, EXEMPLARY, OR CONSEQUENTIAL DAMAGES (INCLUDING, BUT NOT LIMITED TO, PROCUREMENT OF SUBSTITUTE GOODS OR SERVICES; LOSS OF USE, DATA, OR PROFITS; OR BUSINESS INTERRUPTION) HOWEVER CAUSED AND ON ANY THEORY OF LIABILITY, WHETHER IN CONTRACT, STRICT LIABILITY, OR TORT (INCLUDING NEGLIGENCE OR OTHERWISE) ARISING IN ANY WAY OUT OF THE USE OF THIS SOFTWARE, EVEN IF ADVISED OF THE POSSIBILITY OF SUCH DAMAGE.

## pcre

PCRE LICENCE

PCRE is a library of functions to support regular expressions whose syntax and semantics are as close as possible to those of the Perl 5 language.

Release 8 of PCRE is distributed under the terms of the "BSD" licence, as specified below. The documentation for PCRE, supplied in the "doc" directory, is distributed under the same terms as the software itself.

The basic library functions are written in C and are freestanding. Also included in the distribution is a set of C++ wrapper functions.

## THE BASIC LIBRARY FUNCTIONS

Written by: Philip Hazel  
Email local part: ph10  
Email domain: cam.ac.uk  
University of Cambridge Computing Service,  
Cambridge, England.  
Copyright (c) 1997-2010 University of Cambridge  
All rights reserved.

## THE C++ WRAPPER FUNCTIONS

Contributed by: Google Inc.  
Copyright (c) 2007-2010, Google Inc. All rights reserved.

## THE "BSD" LICENCE

Redistribution and use in source and binary forms, with or without modification, are permitted provided that the following conditions are met:

- \* Redistributions of source code must retain the above copyright notice, this list of conditions and the following disclaimer.
- \* Redistributions in binary form must reproduce the above copyright notice, this list of conditions and the following disclaimer in the documentation and/or other materials provided with the distribution.
- \* Neither the name of the University of Cambridge nor the name of Google Inc. nor the names of their contributors may be used to endorse or promote products derived from this software without specific prior written permission.

THIS SOFTWARE IS PROVIDED BY THE COPYRIGHT HOLDERS AND CONTRIBUTORS "AS IS" AND ANY EXPRESS OR IMPLIED WARRANTIES, INCLUDING, BUT NOT LIMITED TO, THE IMPLIED WARRANTIES OF MERCHANTABILITY AND FITNESS FOR A PARTICULAR PURPOSE ARE DISCLAIMED. IN NO EVENT SHALL THE COPYRIGHT OWNER OR CONTRIBUTORS BE LIABLE FOR ANY DIRECT, INDIRECT, INCIDENTAL, SPECIAL, EXEMPLARY, OR CONSEQUENTIAL DAMAGES (INCLUDING, BUT NOT LIMITED TO, PROCUREMENT OF SUBSTITUTE GOODS OR SERVICES; LOSS OF USE, DATA, OR PROFITS; OR BUSINESS INTERRUPTION) HOWEVER CAUSED AND ON ANY THEORY OF LIABILITY, WHETHER IN CONTRACT, STRICT LIABILITY, OR TORT (INCLUDING NEGLIGENCE OR OTHERWISE) ARISING IN ANY WAY OUT OF THE USE OF THIS SOFTWARE, EVEN IF ADVISED OF THE POSSIBILITY OF SUCH DAMAGE.

End

# Index

## Numerics

3D glasses	
3D glasses communication range	13
Using the 3D glasses	12
3D Settings	
2D-3D Display Sel. (Select)	28
3D Brightness	28
3D Depth Adjust	28
3D Format	28
Simulated 3D Effect	28
3D video	12

## A

All Reset	27
Anamorphic Lens	31
Aspect	
1.85:1 Zoom	14, 25
2.35:1 Zoom	14, 25
Normal	15, 25
Squeeze	15, 25
Stretch	15, 25
V Stretch	15, 25
Auto Calibration	23

## B

Blanking	25
Brightness	20

## C

Calib. Preset	
Bright Cinema	19
Bright TV	19
Cinema Digital	19
Cinema Film 1	19
Cinema Film 2	19
Game	19
Photo	19
Reference	19
TV	19
User	19
Cinema Black Pro	20
Clear White	21
Color	20
Color Correction	21
Color Space	22
Color Temp. (Temperature)	20
Compatible 3D signals	43
Connecting to Video equipment or a computer	10
Connectors	3
Contrast	20
Contrast Enhancer	20
Control panel	3

## D

DCI specification	40
Dimensions	50
Dynamic Range	28

## E

Expert Setting	21
----------------	----

## F

Film Mode	21
Front/Right side	3

## G

Gamma Correction	21
------------------	----

## H

HDMI Signal Format	29
HDR	22
High Altitude Mode	26
Hue	20

## I

Image Flip	31
Input Lag Reduction	22
Input signals and adjustable/setting items	43
Intake Air Temp.	33
IR Receiver	31

## L

LAN connector	34
Language	26
Laser Light Setting	20
Lens adjustment window	9
Lens Control	31
Location of controls	
Front	3
Rear/Bottom	4

## M

Menu	
Advanced Picture	23
Function	28
Information	33
Installation	31
Operation	17
Picture	19
Screen	24
Setup	26
Menu Position	26
Messages	
Caution	39
Warning	39
Motionflow	20
MPEG NR (MPEG Noise Reduction)	21

## N

Network Features	34
Network Management	26
Network Setting	32
NR (Noise Reduction)	21

## P

Panel Alignment	32
Periodic LD Calibration	26
Picture Position	
Picture Position	24
Using the Picture Position	13
Picture position adjustment	6
Picture Viewing Mode	16
Power Saving	27
Preset memory	33

## Preset mode

BRT CINE	16
BRT TV	16
CINEMA DIGITAL	16
CINEMA FILM 1	16
CINEMA FILM 2	16
GAME	16
PHOTO	16
REF	16
TV	16
USER	16

Preset signals	42
Projecting the Picture	12
Projection distance	47, 48, 49
Projection distance and lens shift range	46

## R

Reality Creation	19
Remote control	
Location of buttons	5
Remote control detector	4
Remote Start	26
Reset	19
Resetting the items	18

## S

Settings Lock	29
Sharpness	20
Signal type	33
Simulated 3D feature	40
Smooth Gradation	21
Software Version	33
Specifications	41
Status	26

## T

Test Pattern	29
Trigger Select	31
Troubleshooting	36
Turning off	12
Turning on	7

## U

Updating the software	40
-----------------------	----

## W

WARNING indicator	38
-------------------	----

## X

x.v.Color	22, 40
-----------	--------

